

DC430 ECONOMICAL CHAIR

OPERATING INSTRUCTIONS



FEATURES

- **Height Adjustment**

To raise seat, remove pressure from seat and lift lever (1). To lower seat height, sit on chair and lift lever (1).

- **Backrest Height Adjustment**

Loosen upper knob on Backrest post to raise or lower the height of Backrest.

TIGHTEN KNOB COMPLETELY !

- **Seat Depth Adjustment**

Loosen knob underneath chair, slide Back assembly in or out to desired position.

TIGHTEN KNOB COMPLETELY !

WARNING

1. Use this product only one person at a time.
2. Do not use this chair unless all bolts, screws, and knobs are securely tightened.
3. Check that all bolts, screws, and knobs are tight every three months or as needed.
4. Dispose of packing material properly. Do not use plastic cover as head covering. It may cause suffocation.
5. Do not use this chair as a stepladder.
6. Use this chair for its intended purpose only.
7. Use mild detergent only for cleaning.

Warranty

15 Year limited warranty on all non moving metal parts. Swivel mechanisms, pneumatic cylinder, plastic parts, base and casters for 5 years. Upholstery fabric against wear and deterioration for 3 years.

To make a warranty claim, contact Parts Department. Provide model number and description of the problem and obtain return authorization.

At it's option Office Star Products will: (a) Supply compatible components of current manufacture. (b) Repair the customer's component. The customer must prepay freight on any components returned to the factory. Return freight on components still in warranty will be paid by Office Star Products.

This warranty will not cover labor, freight or damage caused by neglect, abuse, mis-use, alterations, or damage caused by shipment, fire, or flood.

All warranties are limited to the original purchaser for normal commercial usage defined as a standard forty hour work week by persons weighing 250 lbs. or less. When usage exceeds 40 hours per week, a two year warranty on all parts applies. Fabric is warranted for one year.

Our quality standards are among the highest in the industry. Sometimes, no matter how hard we try, there are times when parts are damaged or missing. Our Parts Department will do everything possible to promptly remedy the problem. Contact us via email parts@officestar.net, by Fax 1-909-930-5629, or toll free parts number 1-800-950-7262, Monday through Friday 8:00 a.m. - 5:00 p.m. Pacific Time.



DC430 ECONOMICAL CHAIR

ASSEMBLY INSTRUCTIONS

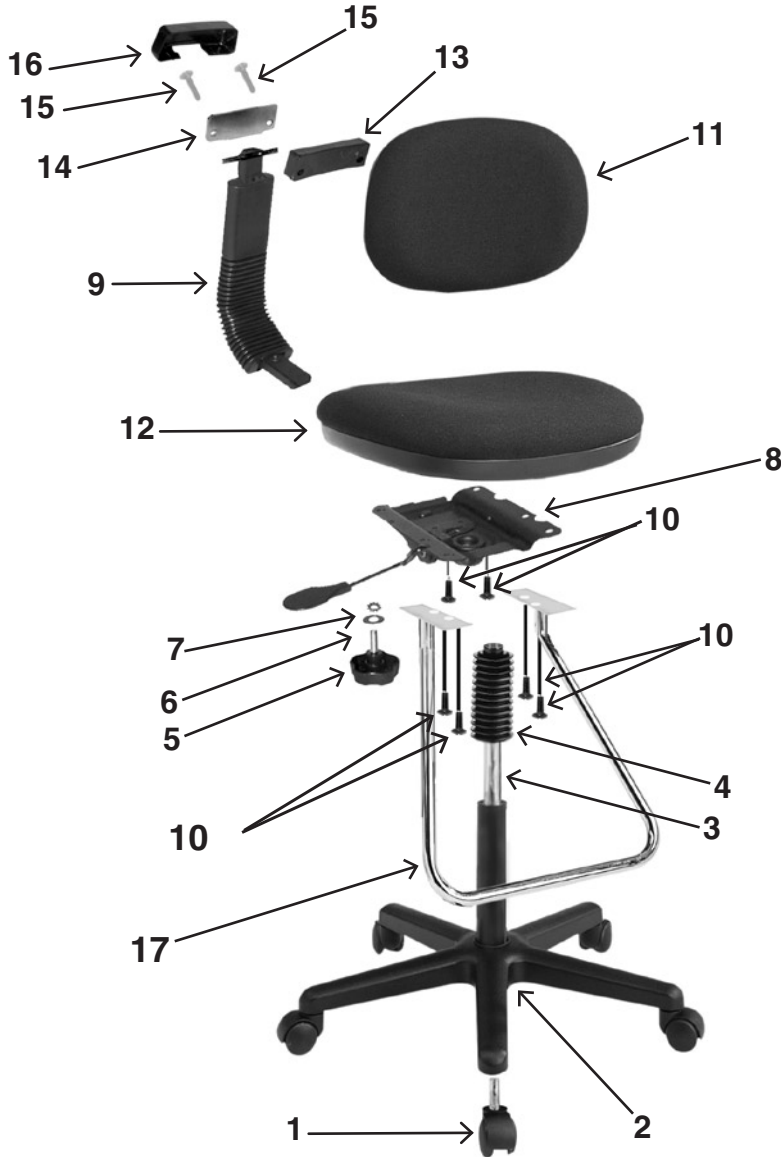

Parts	Qty.
1. Casters	5
2. Base	1
3. Pneumatic Cylinder	1
4. Plastic Bellows	1
5. Backrest Depth Adjustment Knob	1
6. Flat Washer	1
7. Lock Washer	1
8. Mechanism	1
9. Back Frame	1
10. Small Machine Screws	6
11. Back Rest	2
12. Seat	1
13. Backrest Plastic Plate	1
14. Backrest Metal Plate	1
15. Large Machine Screws	2
16. Backrest Plastic Cover	1
17. Tear Drop Footrest	1

Remove all parts from carton, separate them into part numbers as indicated on the Parts List and make sure part quantities are correct.

STEP 1 Insert five Casters (1) into Base (2). Be sure all casters are inserted and locked into place.

STEP 2 Insert Pneumatic Cylinder (3) into Base (2), slide plastic Bellows (4) over Pneumatic Cylinder (3).

STEP 3 Align holes of Back Rest (11) to Backrest Plastic Plate (13). Place Back Frame (9) flush into Backrest Plastic Plate (13), align Backrest Metal Plate (14) and secure assembly with two Large Machine Screws (15).

FULLY TIGHTEN SCREWS. Cover with Backrest Plastic Cover (16).

STEP 4 With arrows facing the front of chair align pre-drilled holes of Mechanism (8) to Seat (12) secure using two Small Machine Screws (10) in the back two predrilled holes. Align Footrest (17) to remaining holes of Mechanism (8), making sure the Footrest (17) is angled toward the front of chair, secure with four Small Machine Screws (10). **FULLY TIGHTEN ALL SCREWS.**

STEP 5 Slide Back Frame (9) with attached Back Rest (11) between Seat (12) and Mechanism (8). Secure with Backrest Depth Adjustment Knob (5) through Flat Washer (6) and Lock Washer (7).

FULLY TIGHTEN KNOB.

Place Upper assembled portion of chair onto Pneumatic Cylinder (3) and apply downward pressure.

ATTENTION: MAKE SURE ALL SCREWS ARE FULLY TIGHTENED BEFORE USING CHAIR.