

DA-SNAP®

Wall-Mounted Projection Screen

When ordering, make appropriate selections:

- 1 Select size from charts at the lower right.
- 2 Select viewing surface:
 - Da-Mat™
 - High Contrast Da-Mat™
 - Cinema Vision
 - High Contrast Cinema Vision
 - Pearlescent
 - High Power
 - Audio Vision
 - High Contrast Audio Vision
 - High Contrast Cinema Perf
 - Da-Tex™ (Rear)
 - Dual Vision

- 3 Options:
 - Pro-Trim Light Absorbing Viewing System is a fabric covering that aesthetically enhances the appearance of the installation. Pro-Trim provides a stylish masked border while absorbing the light that surrounds the viewing area.
 - Velcro® attachment.



- High quality fixed frame screen.
- Front or rear projection.
- 1-1/2" square aluminum tube frame.

SUGGESTED SPECIFICATIONS:

_____ projection screen, _____ (H) x _____ (W), wall mounted type. To have flexible screen surface of Da-Mat, High Contrast Da-Mat, Cinema Vision, High Contrast Cinema Vision, High Contrast Cinema Perf, Pearlescent, Audio Vision, High Contrast Audio Vision, High Power, Da-Tex or Dual Vision. All screen surfaces are fire and mildew resistant. Screen surface standard with reinforced black webbing on all four sides and will attach to frame with metal snaps, Velcro optional. Frame will conceal snaps and webbing. Screen frame will be 1-1/2" square matte black powder coated 6063-T5 aluminum with .062 walls. Walls will be ribbed for strength and light weight. Frame will be slip-jointed at corners and side sections. Corners will be welded and connecting plugs are riveted together. Standard wall-mounting brackets will be included.

All surfaces will be seamless in all standard sizes. Audio Vision, High Contrast Audio Vision and High Contrast Cinema Perf surfaces are available in sizes up to 8' high. High Power surface is available in sizes up to 6' high. **All viewing surfaces are standard with black backing except Da-Tex and Dual Vision.**

Detailed dimensional drawings and installation instructions available upon request. Specifications subject to change without notice.

Da-Snap® Shown From Back Side

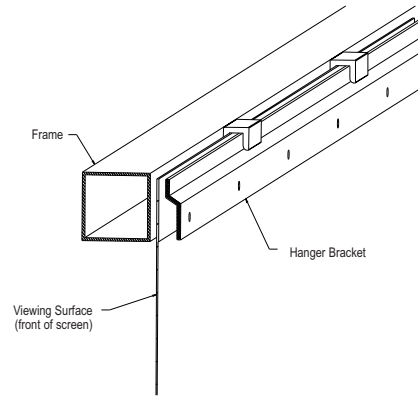
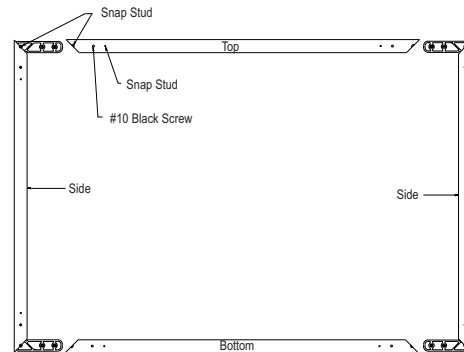

VIDEO FORMATS

Viewing Area H x W	Nominal Diagonal Size	Overall Dimensions H x W	Approx. Shipping Wt. Lbs.
36" x 48"	60"	39" x 51"	19
43" x 57-1/2"	72"	46" x 60-1/2"	22
50-1/2" x 67"	84"	53-1/2" x 70"	24
57-1/2" x 77"	96"	60-1/2" x 80"	28
60" x 80"	100"	63" x 83"	30
72" x 96"	120"	75" x 99"	36
90" x 120"	150"	93" x 123"	44
108" x 144"	180"	111" x 147"	50
120" x 160"	200"	123" x 163"	75
144" x 192"	240"	147" x 195"	90

HDTV FORMATS

Viewing Area H x W	Nominal Diagonal Size	Overall Dimensions H x W	Approx. Shipping Wt. Lbs.
37-1/2" x 67"	77"	40-1/2" x 70"	26
40-1/2" x 72"	82"	43-1/2" x 75"	26
45" x 80"	92"	48" x 83"	28
49" x 87"	100"	52" x 90"	29
52" x 92"	106"	55" x 95"	30
54" x 96"	110"	57" x 99"	30
58" x 104"	119"	61" x 107"	32
65" x 116"	133"	68" x 119"	34
78" x 139"	159"	81" x 142"	40
94-1/2" x 168"	193"	97-1/2" x 171"	75
108" x 192"	220"	111" x 195"	90

Overall frame dimensions ± 1/4".

Note: Letterbox format and custom sizes available upon request.