

ADVANTAGE MANUAL with CSR (Controlled Screen Return)

Manual Screen With CSR (Controlled Screen Return)

When ordering, make appropriate selections:

- 1 Select size from charts at the lower right.
- 2 Select viewing surface:
 - Matte White
 - High Contrast Matte White
 - Video Spectra®1.5
 - Glass Beaded
 - High Power
- 3 Options:
 - No Borders (Black masking borders standard).
 - Pull Rod.
 - Black "Extra Drop" to lower picture area more than normal. Maximum total drop 13' including picture area.
 - White "Extra Drop" to lower picture area more than normal. Maximum total drop 13' including picture area.



- Manual screen for ceiling recessed applications.
- Designed and developed with the installer and the installation process in mind.
- You can choose to receive the case and fabric together or have them sent separately to ensure that the screen surface is not damaged during the "rough-in" stages of construction.

SUGGESTED SPECIFICATIONS:

_____ projection screens, _____ (H) x _____ (W), recessed ceiling mounting type. To have Glass Beaded, Matte White, High Contrast Matte White, Video Spectra® 1.5 or High Power surface with black masking borders standard on flame retardant and mildew resistant fabric, mounted on a ball bearing rigid steel spring roller (1-3/4" diameter for widths 70" or less, 3" diameter for widths 84" and over). To be equipped with Controlled Screen Return (CSR) to control the return speed of the screen surface back into the case. Fabric to be permanently attached to roller by metal clips on fabric edge being forced into groove in roller. There shall be a clip every 3" along the fabric edge and double clips shall be used on the ends. Top, front, and back of case to be made of extruded aluminum. End caps to be of heavy gauge steel with provisions for attaching mounting hardware. Bottom of case to have a removable access door. Entire case to be painted white. Bottom of case to be self-trimming, with a built-in flange around the bottom of the case. Bottom of screen shall be formed into pocket holding tubular metal slat. An extruded aluminum saddle with zinc plated steel pull shall be attached to the slat by four screws on each end. Heavy-duty plastic caps shall protect the ends of the slat. Metal bumper stops, padded with sponge rubber, shall be built into the case to prevent slat wedging inside case. Roller mounting brackets to be adjustable to allow centering or offsetting the screen within the case. Suitable for use in environmental air space in accordance with section 300-22 (c) of the National Electric Code, and sections 2-128, 12-010 (3) and 12-100 of the Canadian Electrical Code, part 1, CSA C22.1.

Matte White: Horizontal seam required when both dimensions exceed 10'.
 Glass Beaded: Horizontal seam required when both dimensions exceed 8'.
 Video Spectra®1.5 and High Contrast Matte White: Available in sizes where both dimensions do not exceed 8'.
 High Power: Available in sizes up to and including 9'x12'. Horizontal seam required when both dimensions exceed 6'.

Detailed dimensional drawings, wiring diagrams and installation instructions available upon request. Specifications subject to change without notice.

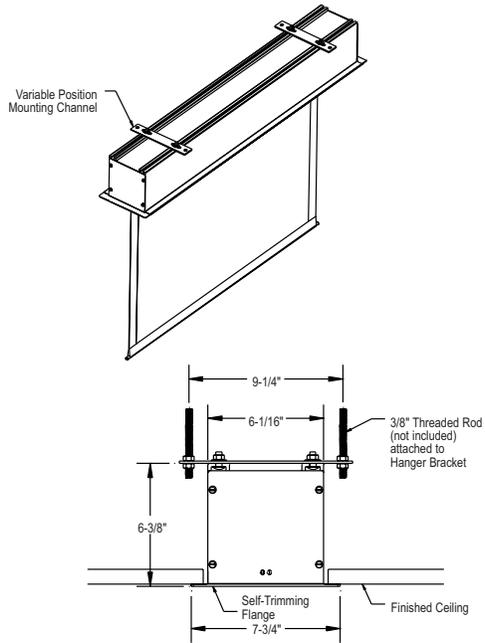

VIDEO FORMATS

Viewing Area H x W	Nominal Diagonal	Overall Case Length	Approx. Shipping Wt. Lbs.
43" x 57"	72"	65-1/2"	59
50" x 67"	84"	75-1/2"	63
57" x 77"	96"	89-1/2"	66
60" x 80"	100"	89-1/2"	71
69" x 92"	120"	101-1/2"	83
87" x 116"	150"	125-1/2"	100
105" x 140"	180"	149-1/2"	110
120" x 160"	200"	169-1/2"	127

HDTV FORMATS

Viewing Area H x W	Nominal Diagonal	Overall Case Length	Approx. Shipping Wt. Lbs.
45" x 80"	92"	89-1/2"	71
52" x 92"	106"	101-1/2"	77
54" x 96"	110"	105-1/2"	80
58" x 104"	119"	113-1/2"	89
65" x 116"	133"	125-1/2"	91
78" x 139"	159"	149-1/2"	119

DIMENSIONS

Sizes H x W	Overall Case Length	Approx. Shipping Wt. Lbs.
60" x 60"	65-1/2"	60
70" x 70"	75-1/2"	66
84" x 84"	89-1/2"	75
6' x 8'	101-1/2"	78
8' x 8'	101-1/2"	82
7' x 9'	113-1/2"	86
9' x 9'	113-1/2"	93
8' x 10'	125-1/2"	101
10' x 10'	125-1/2"	105
9' x 12'	149-1/2"	108
12' x 12'	149-1/2"	123

Overall case length dimensions ± 1/4".
 Note: Letterbox formats and custom sizes available upon request.

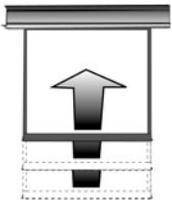

The CSR (Controlled Screen Return) will allow operator to release screen from the full down position. The screen will "fast travel" to within approximately 2' of the case. The screen will then slow down and coast into the case without damage to the fabric.