

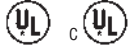

**SPECIFICATION DATA**

**SUGGESTED SPECIFICATIONS:** \_\_\_\_\_ projection screens, \_\_\_\_\_ (H) x \_\_\_\_\_ (W), electrically operated 120 volt A.C. (60 Hz). Screen will have 2.6 amp. motor. Three wire quick reversal motor especially designed for the purpose, to be oiled for life, with automatic thermal overload cutout and integral interlocking gears. To have preset but adjustable limit switches to automatically stop screen fabric in the "up" and "down" positions. Stop action to be positive to prevent coasting. Rigid metal roller, to be at least 3" in diameter (on screens 12' wide), 5¾" in diameter (on screens 14' to 18' wide) or 7" in diameter (on screens where either height or width equal or exceed 20'). Roller to be mounted in one heavy duty bracket equipped with self-aligning bearing. Motor to be mounted inside of roller, secured to the case with a steel motor mount bracket. Screen surface to be flame retardant and mildew resistant. Glass Beaded or Matte White with black masking borders standard. Case to be of wood, with double top for extra rigidity and strength. Case to be finished with a black primer coat, ready to accept final finish by others, heavy metal brackets shall be supplied for mounting screen to ceiling or wall. To be complete with 3 position control switch with cover plate. Screen to be listed by Underwriter's Laboratories.



**Matte White:** Horizontal seam required when both dimensions exceed 16'.  
**Glass Beaded:** Horizontal seam(s) required when both dimensions exceed 8'.

**VIDEO FORMAT DIMENSIONS**

Viewing Area		Nominal Diagonal		Overall Length of Case		Approx. Ship. Wt.	
H x W	Cm	In.	Cm	In.	Cm	Lbs.	Kg
120" x 160"	305 x 406	200"	508	174	442	250	113.4
123" x 164"	312 x 417	210"	533	178"	452	260	117.9
141" x 188"	358 x 478	240"	610	202"	513	380	172.4

**HDTV FORMAT DIMENSIONS**

Viewing Area		Nominal Diagonal		Overall Length of Case		Approx. Ship. Wt.	
H x W	Cm	In.	Cm	In.	Cm	Lbs.	Kg
78" x 139"	198 x 353	159"	404	154"	391	259	117.5
92" x 164"	234 x 417	188"	478	178"	452	266	120.7
106" x 188"	269 x 478	216"	549	202"	513	382	173.3
119" x 212"	302 x 538	243"	617	226"	574	429	194.6
133" x 236"	338 x 599	271"	688	250"	635	835	378.8

**DIMENSIONS**

Sizes		Overall Length of Case		Approx. Ship. Wt.	
H x W	Cm	In.	Cm	Lbs.	Kg
9' x 12'	274 x 366	154"	391	245	111.1
12' x 12'	366 x 366	154"	391	251	113.9
10'6" x 14'	320 x 427	178"	452	266	120.7
14' x 14'	427 x 427	178"	452	266	120.7
12' x 16'	366 x 488	202"	513	382	173.3
16' x 16'	488 x 488	202"	513	382	173.3
13'6" x 18'	411 x 549	226"	574	429	194.6
18' x 18'	549 x 549	226"	574	429	194.6
15' x 20'	457 x 610	250"	635	835	378.8
20' x 20'	610 x 610	250"	635	845	383.3
11' x 22'	335 x 671	274"	696	901	408.7
16'6" x 22'	503 x 671	274"	696	911	413.2
22' x 22'	671 x 671	274"	696	921	417.8
12' x 24'	366 x 732	298"	757	987	447.7
18' x 24'	549 x 732	298"	757	997	452.2

Detail dimensional drawings, wiring diagrams and installation instructions available upon request.

**DO NOT SEAL IN — ALLOW ACCESS** - Recessed installation requires access to screen roller.

**FOR EXPOSED INSTALLATION** - If the screen is to be mounted in an exposed position, it may be covered with finished plywood, veneer, paneling, plastic wall covering or a valance.

Overall case length dimensions ±¼". Specifications subject to change without notice.

Custom formats and sizes available upon request.

**WHEN ORDERING, MAKE APPROPRIATE SELECTIONS:**

Select size from charts.

**Viewing surface:**

- Matte White
- Glass Beaded

**Options:**

- Black "Extra Drop" to lower picture area more than normal. Maximum total drop 22' including picture area, except for 24' wide, where maximum drop is 18'.
- White "Extra Drop" to lower picture area more than normal. Maximum total drop 22' including picture area, except for 24' wide, where maximum drop is 18'.
- Single Motor Low Voltage Control (LVC).
- Wireless Remote Control for LVC.
  - Radio Frequency Remote.
  - Infrared Remote.
- Key Locking Cover Plate for 120V or LVC Switch.
- Key Operated Switch for 120V only (NOTE: Cannot be used with LVC).
- No Borders (Black masking borders standard).

Project: \_\_\_\_\_

Architect: \_\_\_\_\_

Phone: \_\_\_\_\_

Contractor: \_\_\_\_\_

Phone: \_\_\_\_\_

Supervisor: \_\_\_\_\_

Phone: \_\_\_\_\_

Date: \_\_\_\_\_

Revised: \_\_\_\_\_

- 220 Volt (50 Hz) Motor.
- Video Projector Interface Control.
- External SCB-100 - RS-232 Serial Control Board
  - NET-100 Ethernet-Serial Adapter
- White box (black standard).

**PROFESSIONAL ELECTROL®**  
**SUGGESTED METHODS OF INSTALLATION**

**CEILING TYPE HANGER**

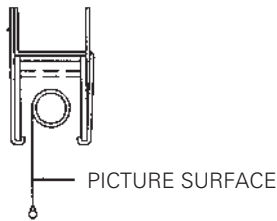

**WALL TYPE HANGER**

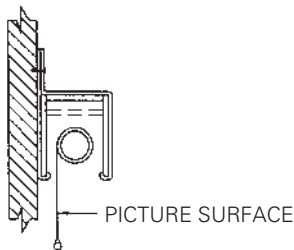

**WALL OR CEILING MOUNT WITH HANGERS**

Wall type hangers and ceiling type hangers are standard equipment. One set is supplied with each screen. Useful for recessed installations.

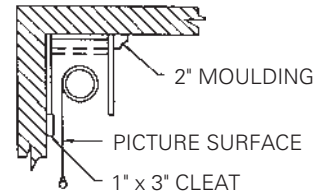

**CEILING MOUNT WITHOUT HANGERS**

Screen case is placed flush with the wall and ceiling and held in position by moulding securely attached to the wall.

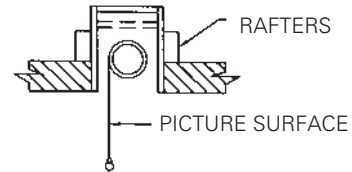

**RECESSED ABOVE CEILING**

Other methods of installation will suggest themselves in new buildings where it would be an easy matter to provide a recess for the screen to conceal it when not in use.

Do not seal in—allow access.

**FOR EXPOSED INSTALLATION**

If the screen is to be mounted in an exposed position, it may be covered with finished plywood, veneer, paneling, plastic wall covering or a valance.

**SCREENS UP TO 18' WIDE  
 (WHERE HEIGHT IS LESS THAN 20')**

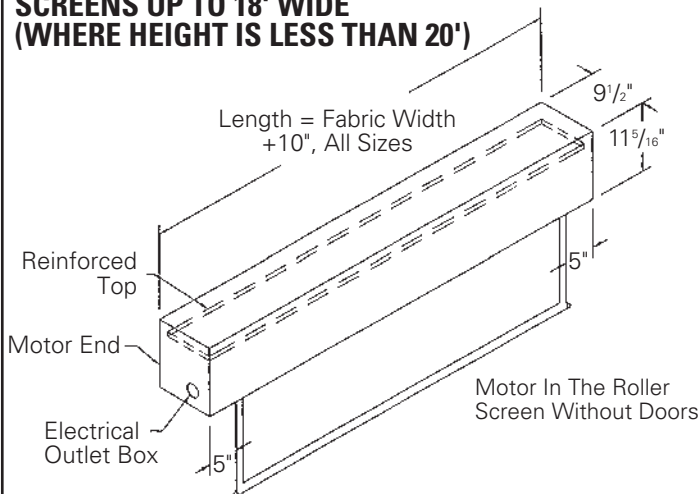

**SCREENS WHERE HEIGHT OR WIDTH  
 EQUALS OR EXCEEDS 20'**

