



# ASCENDER® ELECTROL®

Automatic Electric Projection Screen

## SPECIFICATION DATA

**DA-LITE SCREEN COMPANY, INC.**  
 3100 North Detroit Street  
 Post Office Box 137  
 Warsaw, Indiana 46581-0137  
 Phone: 574-267-8101  
 800-622-3737  
 Fax: 574-267-7804  
 www.da-lite.com  
 e-mail: info@da-lite.com

**SUGGESTED SPECIFICATIONS:** \_\_\_\_\_ projection screens, \_\_\_\_\_ (H) x \_\_\_\_\_ (W), electrically operated 120 volt (60 Hz) 2.6 amp. Fabric to be flame retardant and mildew resistant fiberglass with Matte White, Glass Beaded, Video Spectra 1.5 or High Power® surface with black masking borders standard. To be mounted on 3" diameter rigid steel roller. Screen to be raised vertically by two spring loaded aluminum arms. Shall have a motor mounted inside the roller with a patented noise silencer, to be three wire with quick reversal type, capacitor and an electric brake to prevent coasting. To have preset but adjustable limit switches to automatically stop picture surface in the "up" and "down" position. Case to be made of 3/4" wood and finished with a black primer coat, ready to accept final finishing. Top of case and lid to be covered with black laminate. Safety features to include a lid switch to reverse and stop the screen from rising if the lid does not open. Screen to be operated by low voltage control unit, momentary contact rocker switch, and inputs for optional infrared or radio frequency remote control. To be listed by Underwriters' Laboratories.

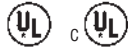

- Matte White:** Seamless in all standard sizes.
- Glass Beaded:** Horizontal seam required when both dimensions exceed 8'.
- Video Spectra 1.5:** Available in sizes where both dimensions do not exceed 8'.
- High Power®:** Available in sizes up to 9' x 12'. Horizontal seam required when both dimensions exceed 6'.

### VIDEO FORMAT DIMENSIONS

Viewing Area		Nominal Diagonal		A - Overall Length of Case		B - Extended Height		C - Leader Height		Approx. Ship. Wt.	
H x W	Cm	In.	Cm	In.	Cm	In.	Cm	In.	Cm	Lbs.	Kg
60" x 80"	152 x 203	100"	254	130"	330	94"	239	15"	38	485	220.0
69" x 92"	175 x 234	120"	305	130"	330	100"	254	12"	30	490	222.3
87" x 116"	221 x 295	150"	381	158"	401	117"	297	11"	28	585	265.4
105" x 140"	267 x 356	180"	457	178"	452	139"	353	15"	38	654	296.7
120" x 160"	305 x 406	200"	508	178"	452	146"	371	6"	15	660	299.4

### HDTV FORMAT DIMENSIONS

Viewing Area		Nominal Diagonal		A - Overall Length of Case		B - Extended Height		C - Leader Height		Approx. Ship. Wt.	
H x W	Cm	In.	Cm	In.	Cm	In.	Cm	In.	Cm	Lbs.	Kg
52" x 92"	132 x 234	106"	269	130"	330	86"	218	15"	38	480	217.7
58" x 104"	147 x 264	119"	302	130"	330	92"	234	15"	38	485	220.0
65" x 116"	165 x 295	133"	338	134"	340	99"	251	15"	38	500	226.8
78" x 139"	198 x 353	159"	404	158"	401	112"	284	15"	38	600	272.2

Overall case length dimensions ±1/4"

12" clearance required from back of screen housing for clearance of extension arms.

#### WHEN ORDERING, MARK APPROPRIATE SELECTIONS:

##### Select size from charts.

##### Select viewing surface:

- Matte White
- Video Spectra 1.5
- Glass Beaded
- High Power®

##### Optional Accessories:

- No borders (Black masking borders standard).
- Wireless Remote Control.
  - Radio Frequency Remote
  - Infrared Remote
- Key Locking Cover Plate for LVC Switch.
- 220 Volt (50 Hz) Motor.
- White box (black standard).

Project:	_____
Architect:	_____
Phone:	_____
Contractor:	_____
Phone:	_____
Supervisor:	_____
Phone:	_____
Supplier:	_____
Date:	_____
Revised:	_____

# ASCENDER® ELECTROL® DIMENSION DETAILS

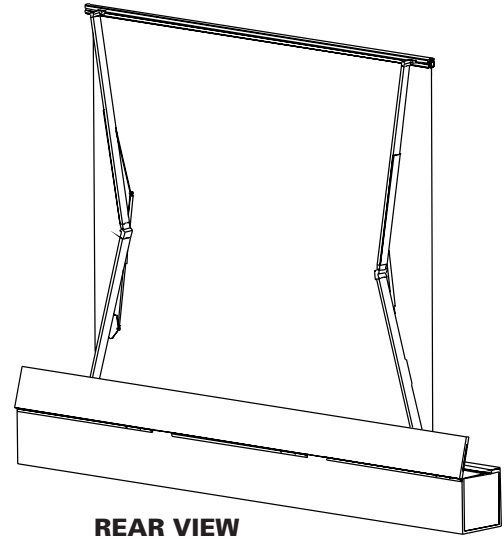
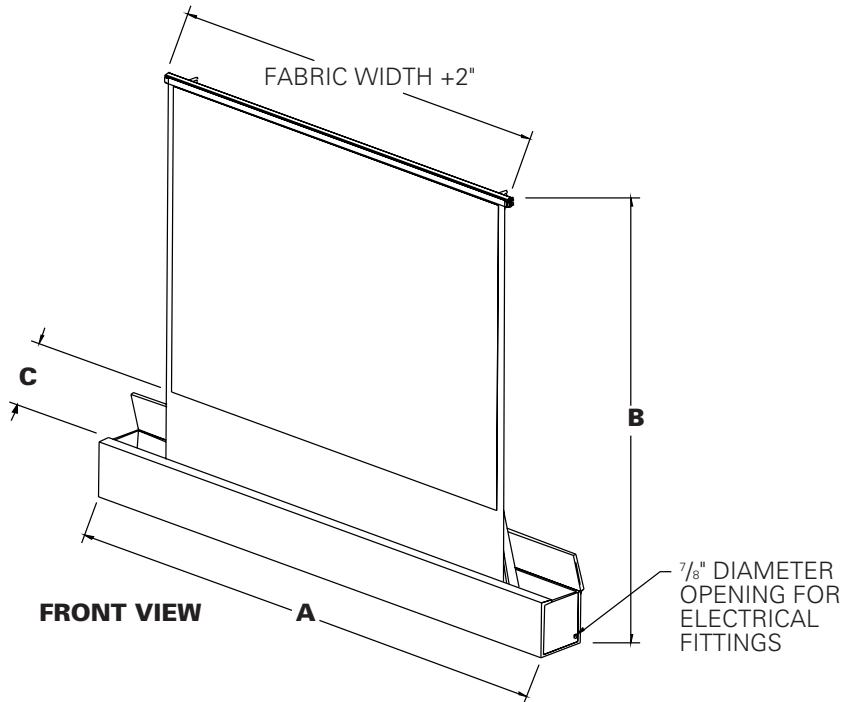

**FIGURE 2**

