



advance



Made In The U.S.A.

DA-LITE SCREEN COMPANY, INC.

3100 North Detroit Street

Post Office Box 137

Warsaw, IN 46581-0137

Phone: 574-267-8101

800-622-3737

Fax: 574-267-7804

877-325-4832

www.da-lite.com

info@da-lite.com

Pivoting Da-Lift 26P and 33P

Form E-453
Rev. 08 / 10

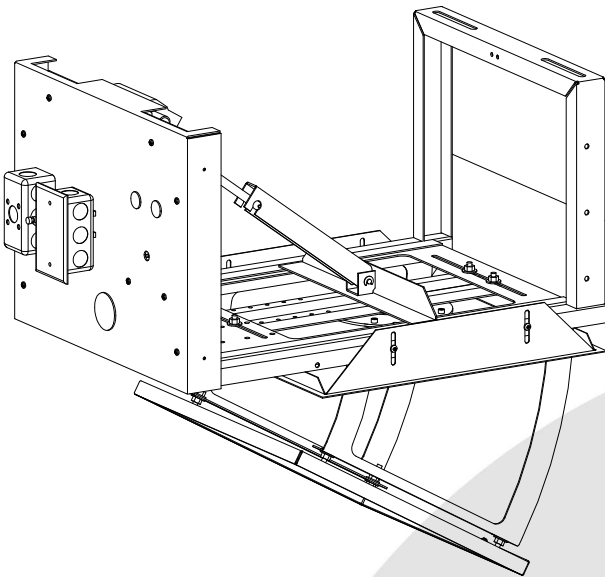

IMPORTANT INSTALLATION NOTES

If installing this unit in "other space used for environmental air", it must be installed with the plenum cover available from Da-Lite Screen.

This unit must be installed in accordance with the requirements of the Local Building Codes, the Canadian Electrical Code (CEC), CAN/CSA C22.1 and the National Electrical Code (NEC), NFPA 70.

Suitable for Use in Other Environmental Air Space in Accordance with Section 300.22(c) of the National Electrical Code, and Sections 2-128, 12-010(3) and 12-100 of the Canadian Electrical Code, Part 1, CSA C22.1.

Caution: This product is designed for ceiling installation only. Qualified personnel using the appropriate fasteners should mount the Pivoting Da-Lift. The surface to which this unit is mounted must be capable of supporting a static load of four times the combined weight of the projector and mount. Do not attach to plaster or drywall alone.

IMPORTANT SAFETY INSTRUCTIONS

When using your video equipment, basic safety precautions should always be followed, including the following:

1. Read and understand all instructions before using.
2. Position the cord so that it will not be tripped over, pulled, or contact hot surfaces.
3. If an extension cord is necessary, a cord with a current rating at least equal to that of the appliance should be used. Cords rated for less amperage than the appliance may overheat.
4. To reduce the risk of electric shock, do not disassemble this appliance. Contact an authorized service dealer when repair work is required. Incorrect reassembly can cause electric shock when the appliance is used subsequently.
5. The use of an accessory attachment not recommended by the manufacturer may cause a risk of fire, electric shock, or injury to persons.

SAVE THESE INSTRUCTIONS

Required Tools:

- 7/16" wrench
- 1/2" wrench
- 9/16" wrench
- Phillips screwdriver

Procedure

- The following procedure is shown with suspended ceiling construction but the Pivoting Da-Lift will work with drywall ceiling. Remove contents from carton and examine for damaged or missing parts.

If installing the Pivoting Da-Lift with a plenum cover, fasten Plenum Cover Bottom to Da-Lift first. See Plenum Cover instruction sheet Steps #1 and #2.

ITEM	DESCRIPTION	QTY
1	DA-LIFT	1
	PACKAGE SET	1
A	CABLE TIE, REUSABLE 7"	6
B	CABLE TIE, 8"	4
C	SCREW, BHSCS 3M X 10mm	4
D	WASHER, FLAT #5	4
E	WRENCH, ALLEN 2mm PIN IN HEX	1
F	WRENCH, ALLEN 5/32"	1
	PACKAGE SET	1
G	SCREW, SHCS M6 X 20mm	4
H	WASHER, FLAT 1/4"	4
J	WRENCH, ALLEN 5mm	1
	PACKAGE SET	1
K	SCREW, SHCS M5 X 20mm	4
L	SCREW, SHCS M4 X 12mm	4
M	WASHER, FLAT #10	4
N	WASHER, FLAT #8	4
P	WRENCH, ALLEN 4mm	1
Q	WRENCH, ALLEN 3mm	1
	PACKAGE SET	1
R	SWITCH, LOW VOLTAGE WALL	1
S	PLATE, WALL SWITCH	1
	PACKAGE SET	1
T	WIPE NUT, ORANGE #20	6
	PACKAGE SET	1
U	SCREW, MACHINE #6-32 X 1"	2

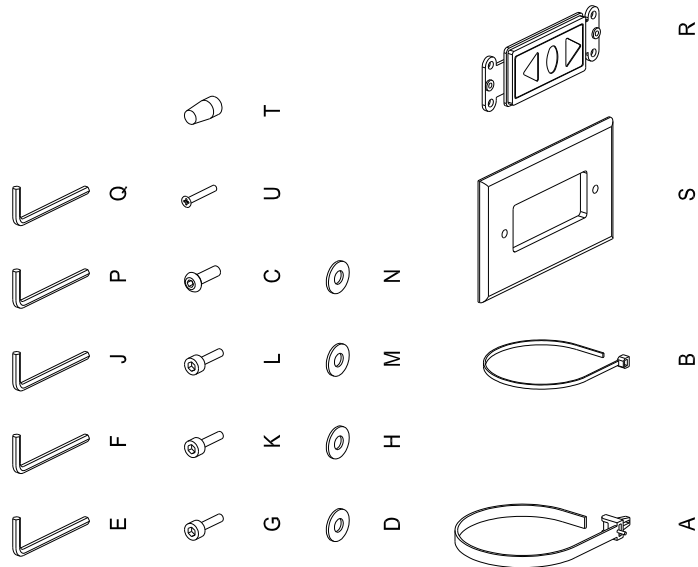
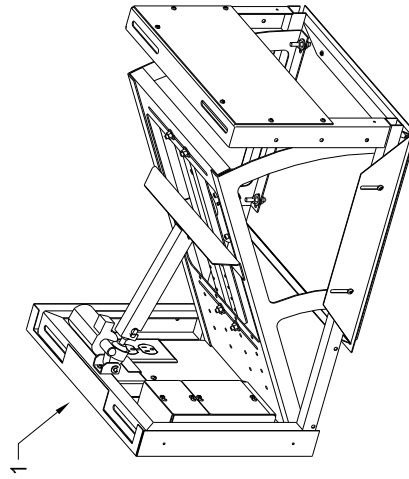

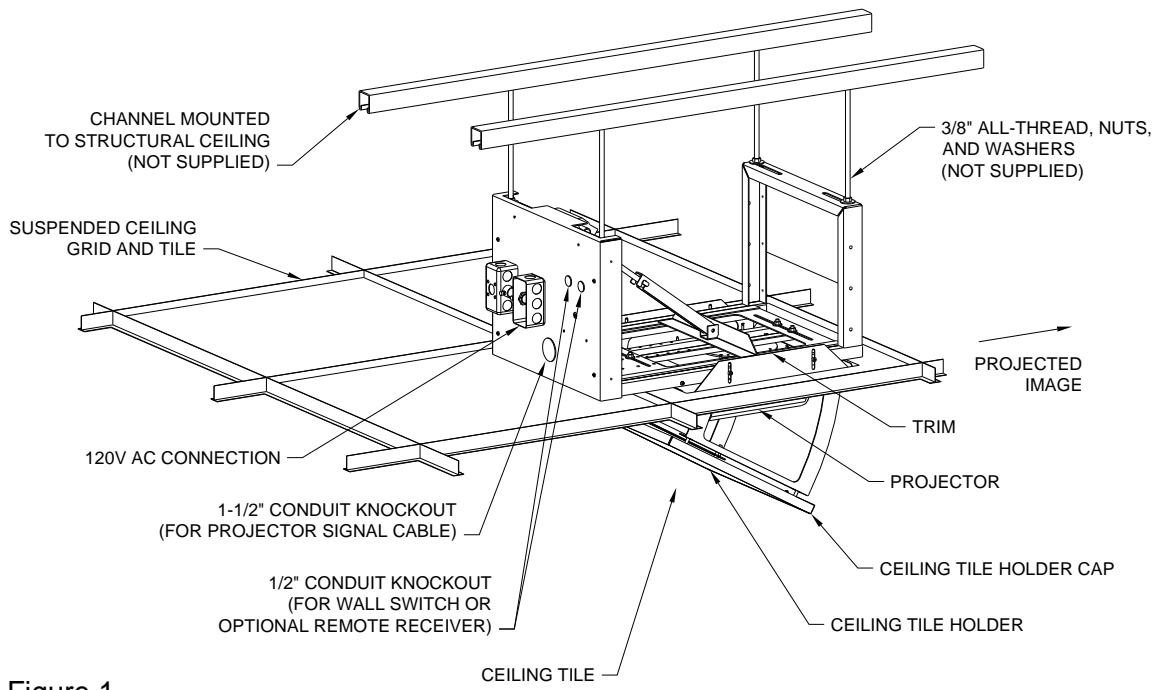

Figure 1

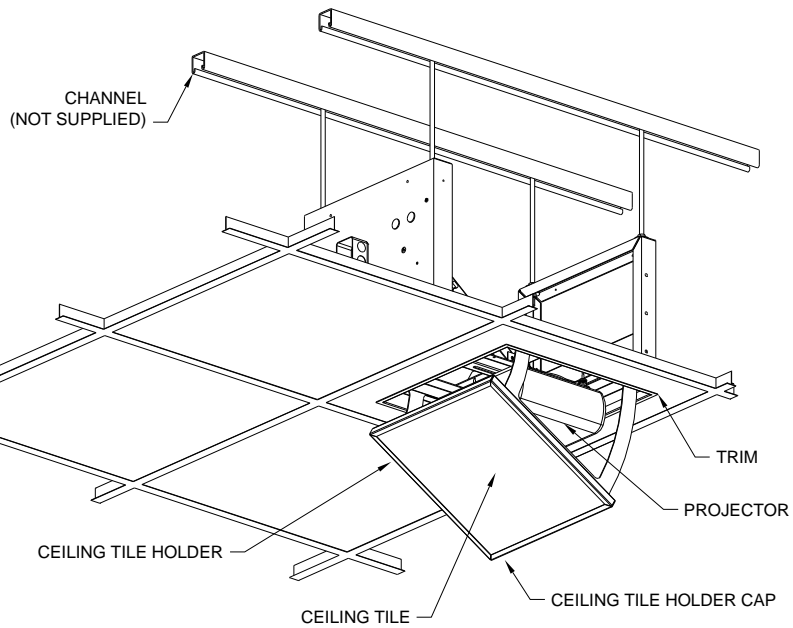

Figure 2

DA-LIFT MODEL	"L"	"W"
26P	23-1/2"	7" TO 14-1/4"
33P	30-1/2"	11-1/2" TO 18-3/4"

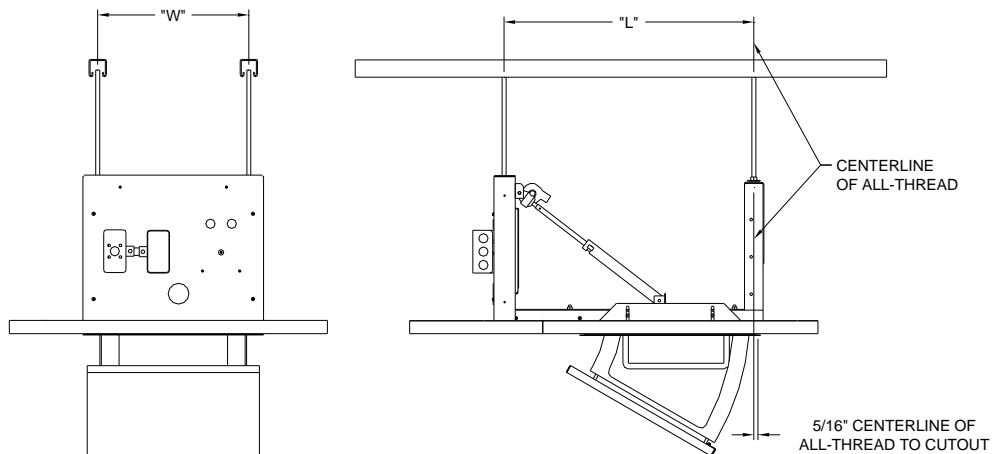
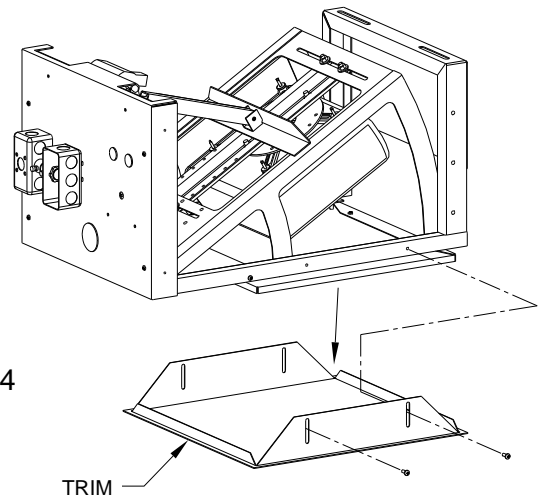

Figure 3

2. Remove Trim piece from Da-Lift. See Figure 4. Save the fasteners.

Figure 4



3. Remove Universal Projector Mount from Da-Lift. See Figure 5. Save the fasteners.

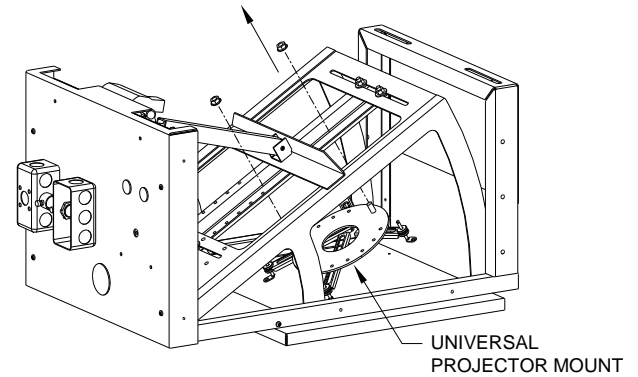

Figure 5

4. Secure Universal Projector Mount to projector. See Figure 6. Thumbnuts can be used for fine-tuning projector position in next step.

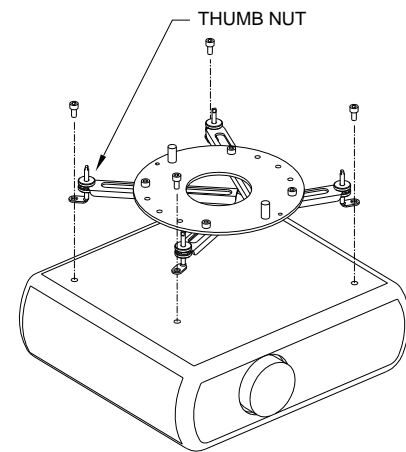

Figure 6

5. Secure the projector and mount to the Da-Lift. Use the features shown to adjust the projector's position. See Figure 3 and 7. Projector lens should not protrude past all-thread centerline.

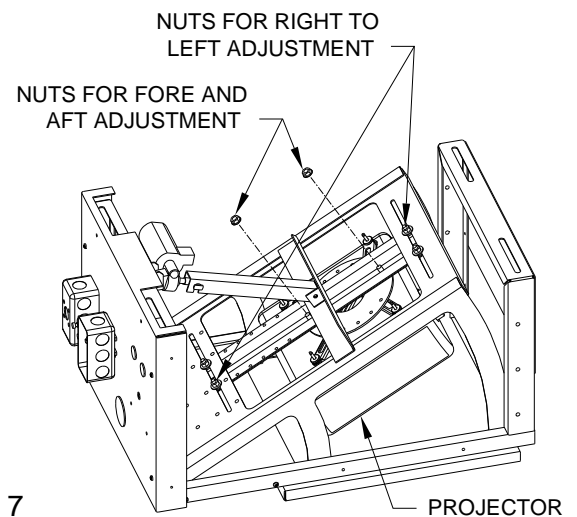

Figure 7

DA-LIFT MODEL	"A"	"B"
26P	16-1/2"	15-3/8"
33P	21"	19-7/8"

- Determine where the projector will be located and make a hole in the ceiling and create a tile for the Da-Lift. See Figure 3 & 8.

NOTE:
CUT-OUTS ARE SQUARE.
TOLERANCES ARE $\pm 1/8"$.

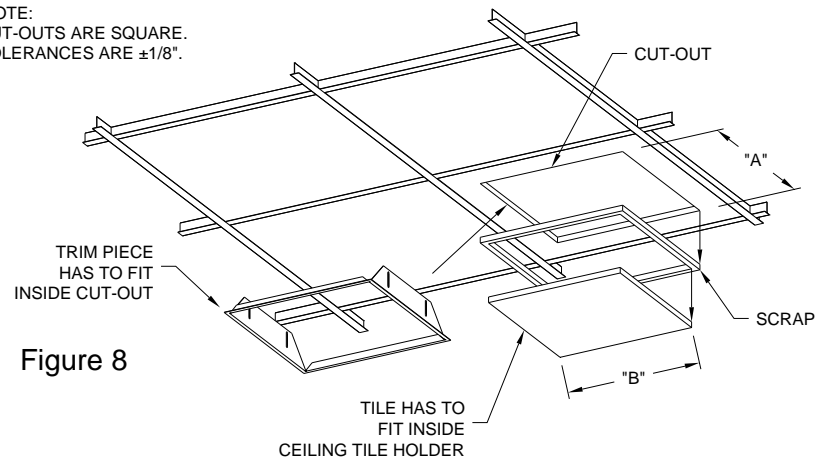

Figure 8

- Attach Da-Lift to structural ceiling. See Figure 9.

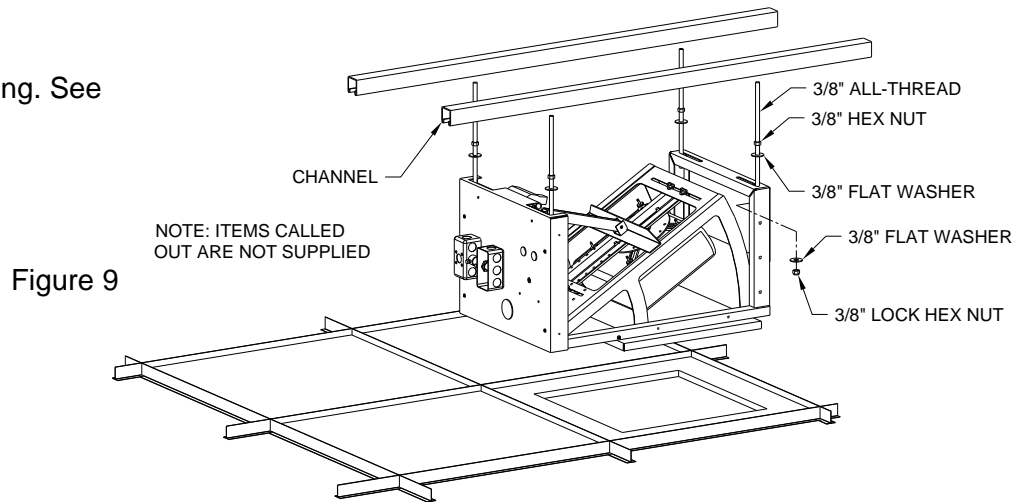

Figure 9

- Lower Da-Lift by connecting the power supply to 120 volt or 220 volt AC power. Use the switch shown to operate the Da-Lift. See Figure 10. The "Stop" button is needed only for intermediate stopping. **WARNING! Avoid pinch points when operating Da-Lift with built-in switch.**
- Power the projector and adjust projector location.

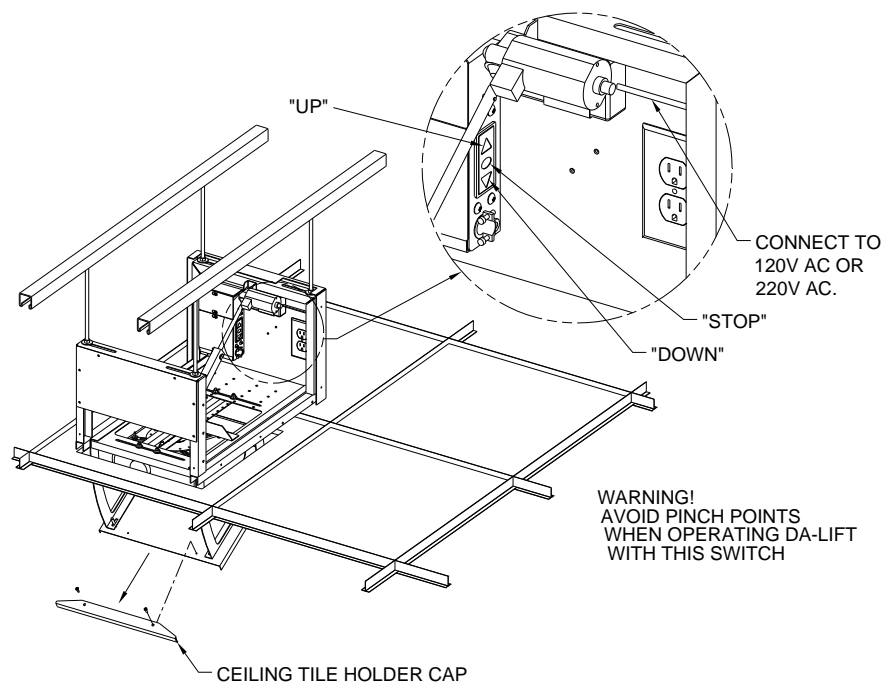

Figure 10

10. Remove Ceiling Tile Holder Cap from Da-Lift. Install Ceiling Tile cutout from step 6 into Ceiling Tile Holder and assemble Ceiling Tile Holder Cap. See Figure 11.

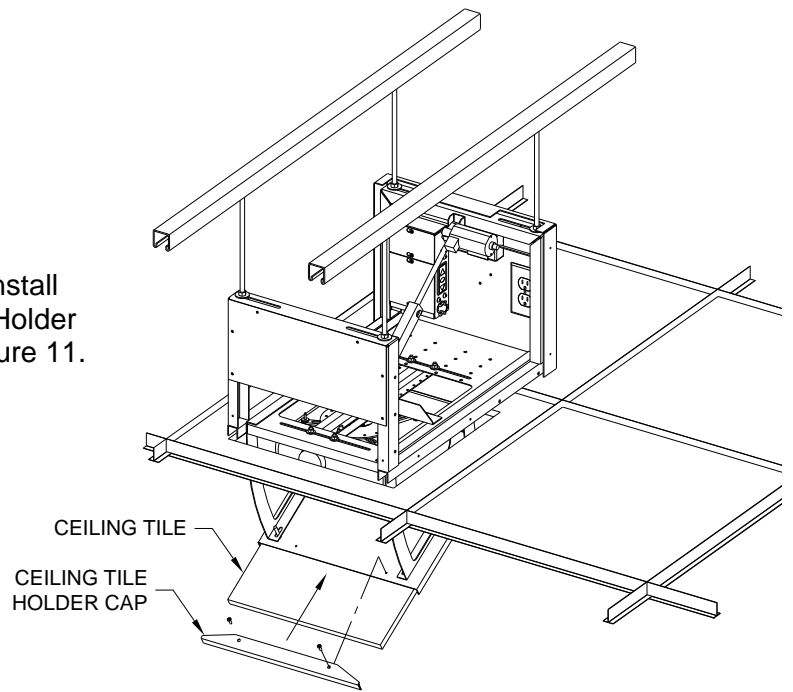

Figure 11

11. Install Trim Piece onto Da-Lift. See Figure 12. May need to adjust position of Ceiling Tile Holder to clear Trim.

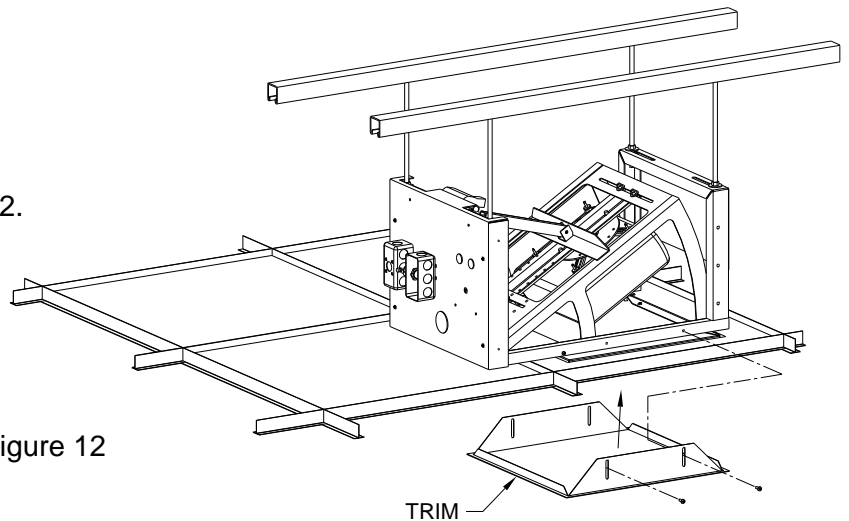

Figure 12

12. Use provided Cable Ties for cable management. See Figure 13. Allow enough slack in the cords for projector movement. If Da-Lift is a 220V version, use the supplied electrical adapter.

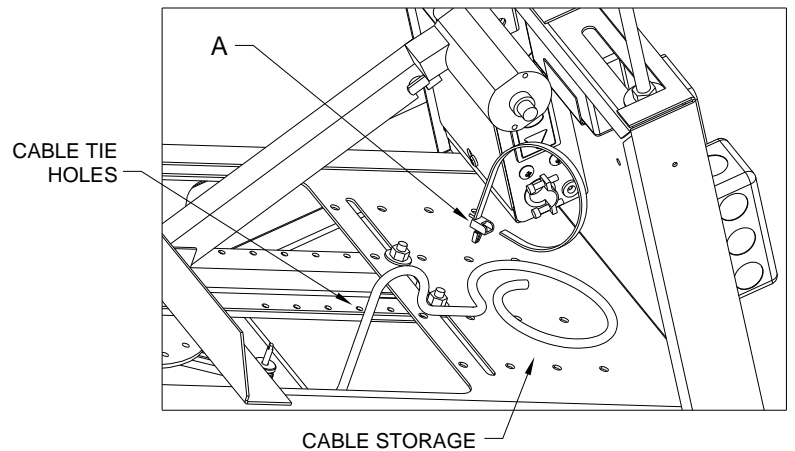
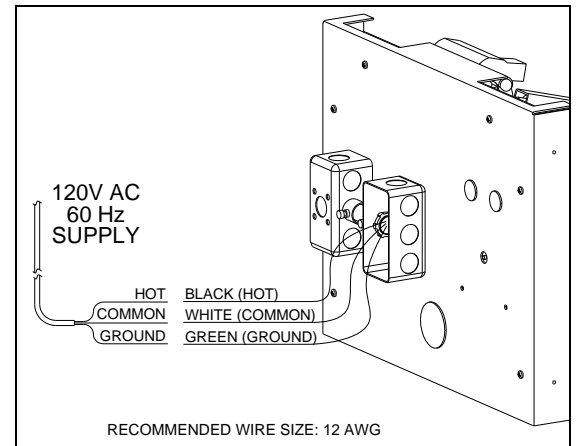

Figure 13

13. Use a licensed electrician to wire the Da-Lift.
See Figure 14 (120 volt) or Figure 15 (220 volt).
Plug the power supply into the receptacle of the Da-Lift.

Figure 14



14. Wire the wall switch supplied with the Da-Lift.
See Figure 16.

Figure 15

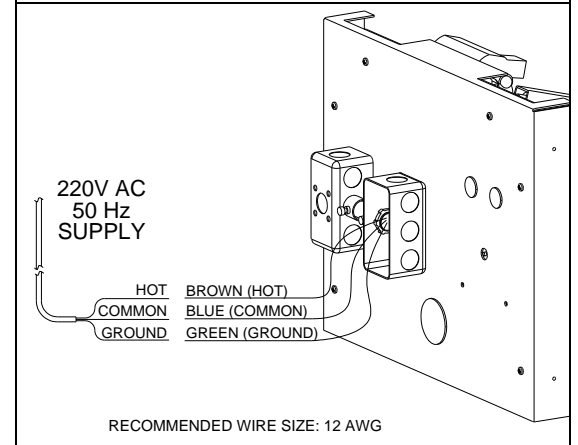

15. A control panel may be connected to the Da-Lift by using the wall switch wire leads. The control panel must provide a momentary, dry contact closure of at least 1/2 second.

- a. Use 3-conductor 20-24 AWG wire to connect the control panel to the wall switch leads. See Figure 16.
- b. A momentary closure across the white and red wires will be an “up” command.
- c. A momentary closure across the white and black wires will be a “down” command.
- d. A momentary closure across the white, red, and black wires will be a “stop” command.

Figure 16

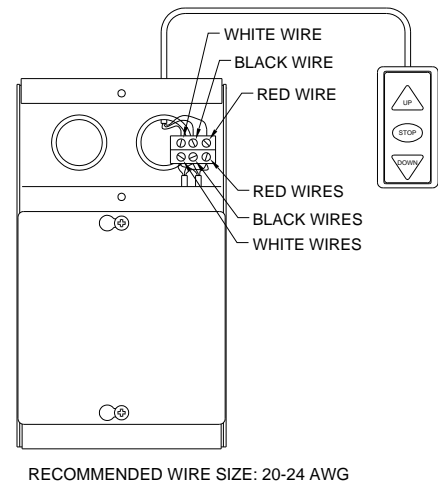

CAUTION: Never apply voltage to the wall switch leads or the Da-Lift will be damaged.

16. Optional Infrared (IR) or Radio Frequency (RF) remote controls are available. To install either remote, remove the Covers from the Control Box. Route the Receiver Cable through the Da-Lift and plastic bushing of the Control Box. Plug the Receiver Cable into the motor control board port labeled “EYE”. See Figure 17. Plug IR or RF receiver into other end of Receiver Cable. “Learn” the RF remote and receiver by following the directions supplied with the RF.

Figure 17

