

*The*  
**POWER** *In*  
**PRESENTATION PRODUCTS**



**Instruction Book for**  
**TENSIONED ADVANTAGE® ELECTROL®**



**DA-LITE SCREEN COMPANY, INC.**

3100 North Detroit Street  
Post Office Box 137  
Warsaw, Indiana 46581-0137  
Phone: 574-267-8101  
800-622-3737  
Fax: 574-267-7804  
Toll Free Fax: 877-325-4832  
www.da-lite.com  
e-mail: info@da-lite.com

## IMPORTANT SAFETY INSTRUCTIONS

When using your video equipment, basic safety precautions should always be followed, including the following:

1. Read and understand all instructions before using.
2. Position the cord so that it will not be tripped over, pulled, or contact hot surfaces.
3. If an extension cord is necessary, a cord with a current rating at least equal to that of the appliance should be used. Cords rated for less amperage than the appliance may overheat.
4. To reduce the risk of electric shock, do not disassemble this appliance. Contact an authorized service dealer when repair work is required. Incorrect reassembly can cause electric shock when the appliance is used subsequently.
5. The use of an accessory attachment not recommended by the manufacturer may cause a risk of fire, electric shock, or injury to persons.

## SAVE THESE INSTRUCTIONS

### PRE-INSTALLATION

1. Carefully unpack case from shipping carton. DO NOT unpack fabric and roller assembly yet.
2. Make sure to recheck measurement of case for proper installation clearance.
3. Remove any protective foam or tape from case.

### CASE INSTALLATION

1. Remove 2 screws to open junction box.
2. Hang case and attach to support structure with threaded rod. See suggested methods of installation on page 5.
3. Tighten bolts until trim flange is flush with ceiling.  
**NOTE: For proper operation, screen assembly must be level after installation.**
4. Install electrical connections that applies to your unit. Make sure to review the wiring diagram for proper hook up.
5. Replace junction box cover and secure with 2 screws.
6. If screen and case are purchased together, remove slat retainer brackets from the screen case and back of slat.

### SCREEN AND ROLLER ASSEMBLY INSTALLATION

If your screen was shipped with the motor and roller already installed, proceed to step 6.

1. Remove access door. First, remove the 2 screws from the ends. Be sure to support the door during this step to avoid injury. Then lift the door slightly and pull away from the edge of the case.
2. Carefully unpack screen and roller assembly. Leave packing paper on roller.
3. To install screen and roller assembly, insert the motor end into the motor mount bracket as shown in Fig. 1.
4. Loosen (but do not remove) two 1/4-20 nuts securing pin end bracket (stage left) to the case housing. Slide the bracket towards the end of the case. Insert the motor end square shaft into the motor end bracket and secure with the clip. Insert the tip of the roller pin end into the bracket and position. Tighten the 1/4-20 nuts securely.
5. Complete electrical hook-up by snapping motor wire connector into case connector.
6. Carefully remove paper and tape from roller assembly. **DO NOT** use a knife or sharp object to cut tape; you will damage the screen.
7. Test installation by running screen up and down a few times. Be prepared to stop screen.
8. Re-install access door. Procedure is reverse of removal (step 1).

 **CAUTION! Excessive continuous operation may cause the motor to overheat. If this happens, the motor will shut off until it cools to a normal operating temperature.**

# TENSIONED ADVANTAGE® ELECTROL® INSTALLATION FOR 120V SCREENS

## 120V WIRING DIAGRAM FOR STANDARD WALL SWITCH

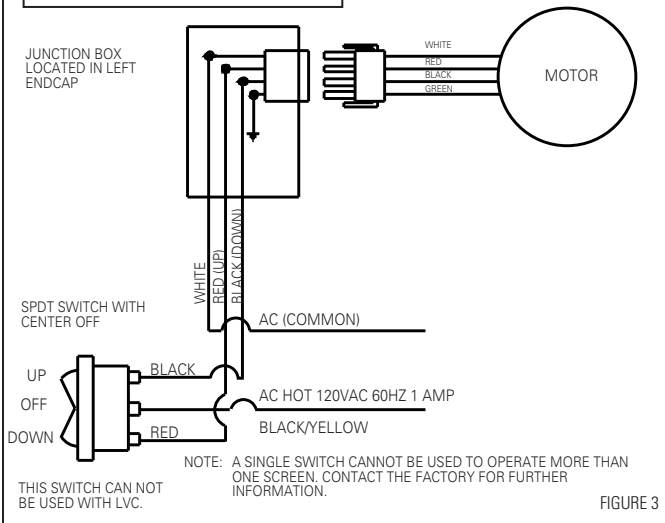

## 120V WIRING DIAGRAM WITH OPTIONAL BUILT-IN VIDEO PROJECTOR INTERFACE

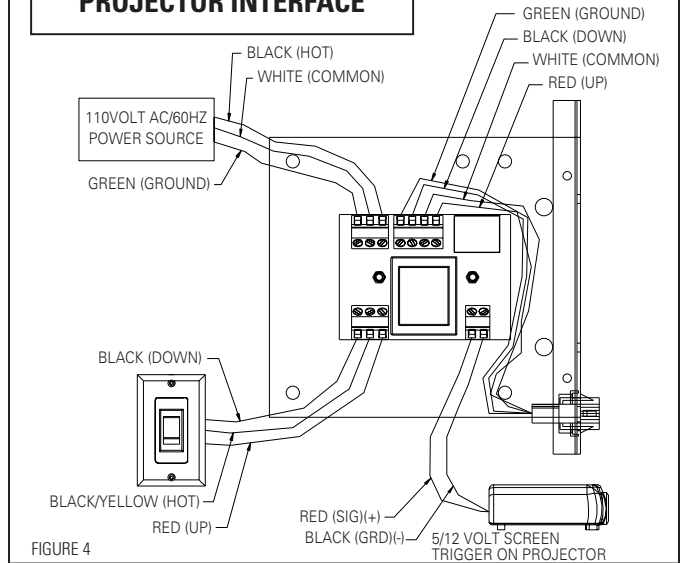

**CAUTION: THE PROJECTOR MUST BE TURNED OFF BEFORE CONNECTING THE TRIGGER WIRES TO THE PROJECTOR. FAILURE TO DO SO MAY DAMAGE THE CONTROLLER.**

1. Use 2-conductor 20-24 gauge wire to extend the low voltage connection from the projector's 5 or 12-volt screen trigger output to the length required to reach the VPI. When extending the low voltage connection from the projector's screen trigger output, be sure to maintain the proper polarity. The red wire from the VPI is the "signal" and the black wire from the VPI is the "ground".
2. Connect the wires from the VPI that are labeled "Low Voltage Connection" to the end of the extended screen trigger wires above.
3. The wall switch must be placed in the "up" position for the screen to be triggered by the projector.
4. If a wall switch is not being used, please do the following. For 120V units, the black/yellow lead and the red lead for the wall switch must be connected to each other and the black lead must be capped. For 240V units, the black/yellow lead and the black lead for the wall switch must be connected to each other and the brown lead must be capped.

## 120V WIRING DIAGRAM WITH OPTIONAL BUILT-IN LOW VOLTAGE CONTROL

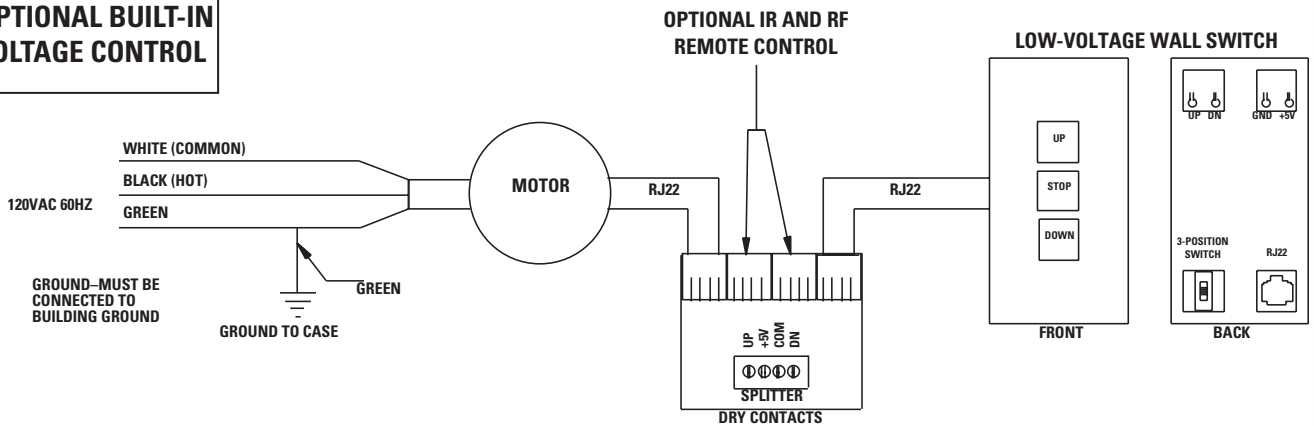

### ILT RJ22 PIN-OUTS (TAB IS FACING UP)

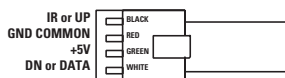

**IMPORTANT NOTE:** The wall switch is REQUIRED to make any limit switch adjustments, EVEN if a third party control system is used. Therefore, it is advised to wire the switch or provide a 4-conductor connection that is accessible.

FIGURE 5

# TENSIONED ADVANTAGE® ELECTROL® INSTALLATION FOR 220/240V SCREENS

## 240V WIRING DIAGRAM FOR STANDARD WALL SWITCH

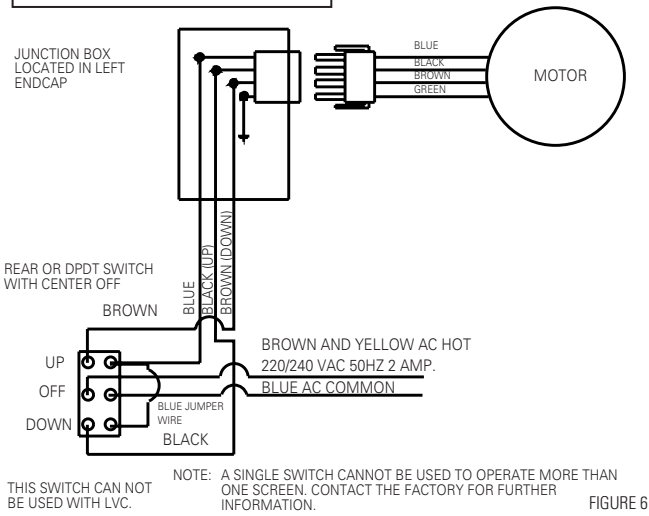

## 240V WIRING DIAGRAM WITH OPTIONAL BUILT-IN VIDEO PROJECTOR INTERFACE

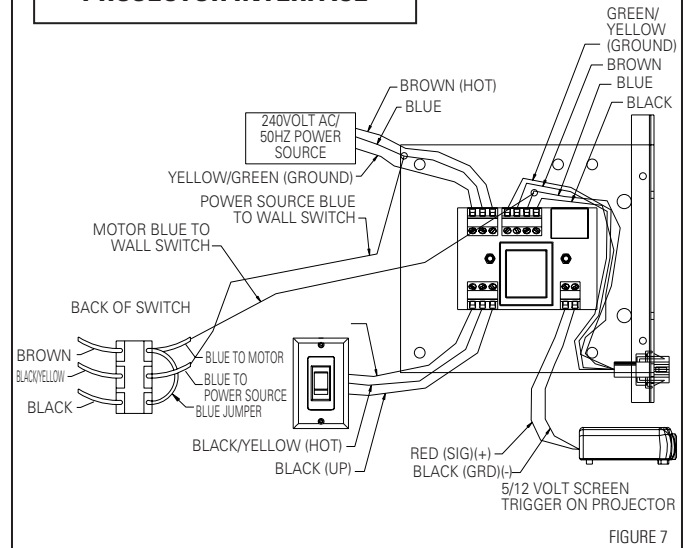

**CAUTION: THE PROJECTOR MUST BE TURNED OFF BEFORE CONNECTING THE TRIGGER WIRES TO THE PROJECTOR. FAILURE TO DO SO MAY DAMAGE THE CONTROLLER.**

1. Use 2-conductor 20-24 gauge wire to extend the low voltage connection from the projector's 5 or 12-volt screen trigger output to the length required to reach the VPI. When extending the low voltage connection from the projector's screen trigger output, be sure to maintain the proper polarity. The red wire from the VPI is the "signal" and the black wire from the VPI is the "ground".
2. Connect the wires from the VPI that are labeled "Low Voltage Connection" to the end of the extended screen trigger wires above.
3. The wall switch must be placed in the "up" position for the screen to be triggered by the projector.
4. If a wall switch is not being used, please do the following. For 120V units, the black/yellow lead and the red lead for the wall switch must be connected to each other and the black lead must be capped. For 240V units, the black/yellow lead and the black lead for the wall switch must be connected to each other and the brown lead must be capped.

## 240V WIRING DIAGRAM WITH OPTIONAL BUILT-IN LOW VOLTAGE CONTROL

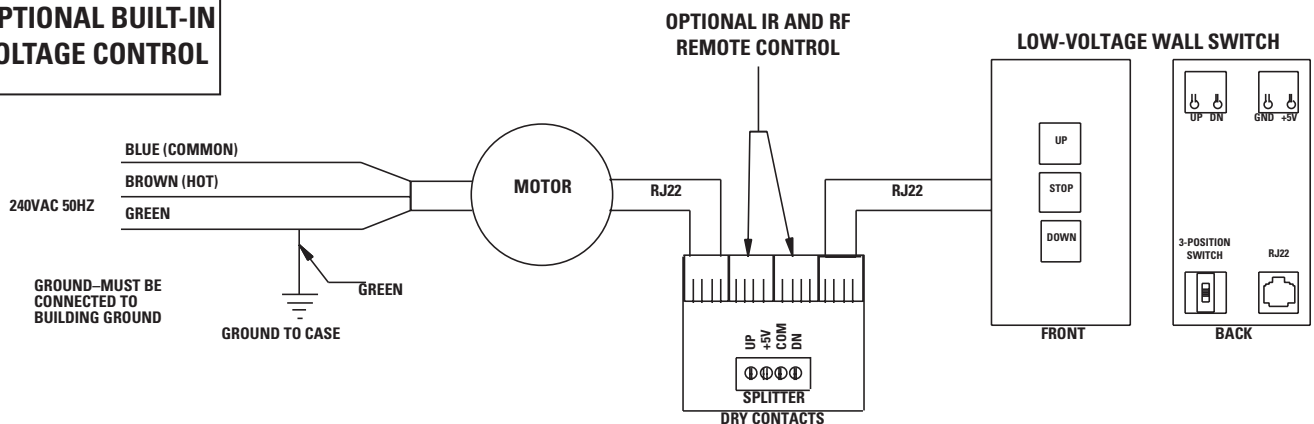

### ILT RJ22 PIN-OUTS (TAB IS FACING UP)

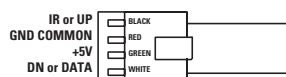

**IMPORTANT NOTE:** The wall switch is REQUIRED to make any limit switch adjustments, EVEN if a third party control system is used. Therefore, it is advised to wire the switch or provide a 4-conductor connection that is accessible.

FIGURE 8

## SCREEN ADJUSTMENT FOR 120V SCREENS WITHOUT BUILT-IN LOW VOLTAGE CONTROL

Surface travel is stopped automatically in the fully opened and closed positions by limit switches that are properly adjusted at Da-Lite. Should it be necessary to adjust for more or less drop of picture, proceed in the following manner: Remove two screws to remove access door.

**NOTE:** Use a screw driver or 5/32" Allen wrench to make adjustments.

### MORE SCREEN DROP

1. Place operating switch in **"down"** position.
2. When the screen stops, turn the white **"down"** limit knob (Fig.1) one turn counterclockwise. Test by raising picture surface approximately two feet, then lower again. Repeat until desired picture surface position is attained.

### LESS SCREEN DROP

1. Raise picture surface approximately two feet above desired level.
2. Place operating switch in **"off"** position.
3. Turn the white **"down"** limit knob (Fig.1) one turn clockwise. Test by raising picture surface approximately two feet, then lower again. Repeat until desired picture surface position is attained.

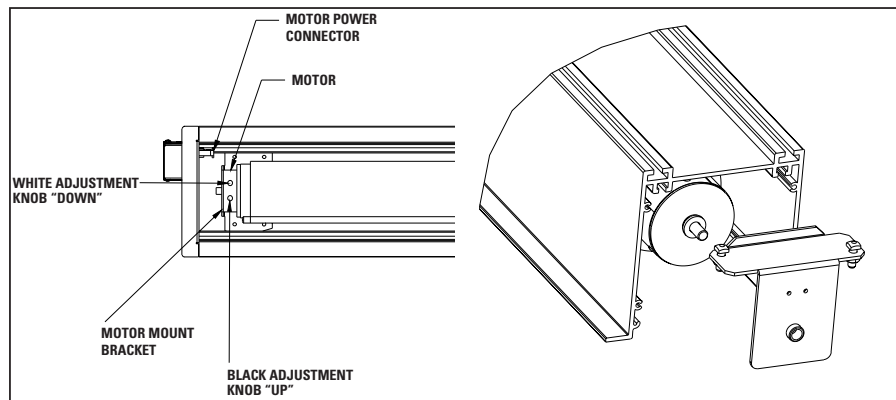

FIGURE 1

## SCREEN ADJUSTMENT FOR 220/240V SCREENS WITHOUT BUILT-IN LOW VOLTAGE CONTROL

Surface travel is stopped automatically in the fully opened and closed positions by limit switches that are properly adjusted at Da-Lite. Should it be necessary to adjust for more or less drop of picture, proceed in the following manner:

**NOTE:** Use a screw driver or 5/32" Allen wrench to make adjustments.

### MORE SCREEN DROP

1. Place operating switch in **"down"** position.
2. When the screen stops, turn the white **"down"** limit knob (Fig.2) one turn counterclockwise. Test by raising picture surface approximately two feet, then lower again. Repeat until desired picture surface position is attained.

### LESS SCREEN DROP

1. Raise picture surface approximately two feet above desired level.
2. Place operating switch in **"off"** position.
3. Turn the white **"down"** limit knob (Fig.2) one turn clockwise. Test by raising picture surface approximately two feet, then lower again. Repeat until desired picture surface position is attained.

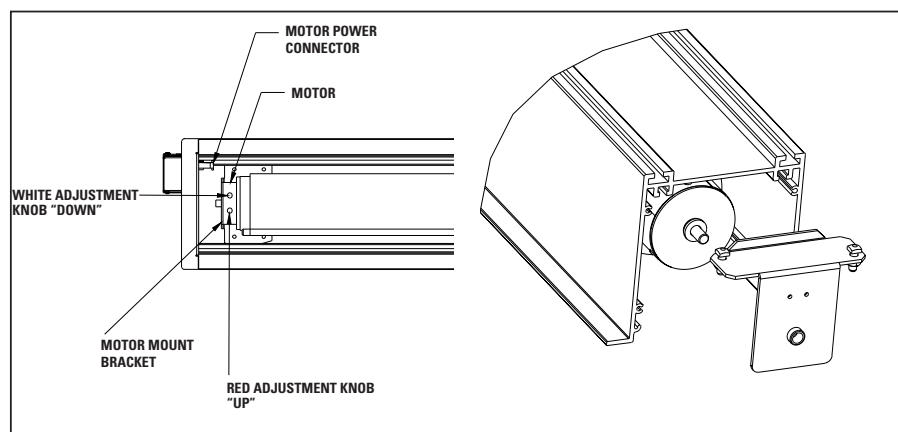

FIGURE 2

## **SCREEN ADJUSTMENT FOR SCREENS WITH A BUILT-IN LOW VOLTAGE CONTROL**

1. Remove the cover plate from the 3-button wall switch and remove the switch from the junction box.
2. Locate small 3-position switch on back of wall switch. See Figure 5 for 120V screens or Figure 8 for 220/240V screens.
3. To adjust the down limit switch, slide the 3-position switch to the down position. Press and hold the down button to run the screen down to the desired stop position. Release the button to stop the screen. **DO NOT PUSH THE STOP BUTTON.**
4. When the screen is in the desired down position, slide the 3-position switch to the off (center) position. The down limit switch is now set.
5. To adjust the up limit switch, slide the 3-position switch to the up position. Press and hold the up button to run the screen up to the desired stop position. Release the button to stop the screen. **DO NOT PUSH THE STOP BUTTON.**
6. When the screen is in the desired up position, slide the 3-position switch to the off (center) position. The up limit switch is now set.
7. To test limit switch setting, make sure the 3-position switch is in the off (center) position. Press and release the up or down button on the wall switch to operate the screen.
8. Replace switch and cover plate on the wall.

**NOTE:** If stop button is pressed, the wall switch will reverse direction. To correct this, press the stop button again. This will reset the switch. You will have to re-set both the up and the down limit settings.

**IMPORTANT NOTE:** The wall switch is **REQUIRED** to make any limit switch adjustments, **EVEN** if a third party control system is used. Therefore, it is advised to wire the switch or provide a 4-conductor connection that is accessible.

**TENSIONED ADVANTAGE® ELECTROL® INSTALLATION**

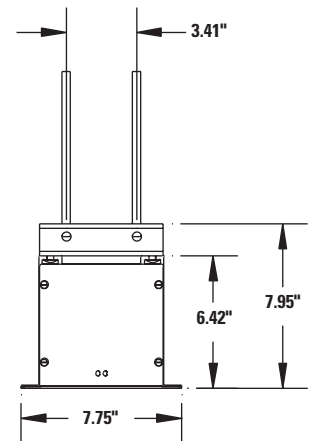
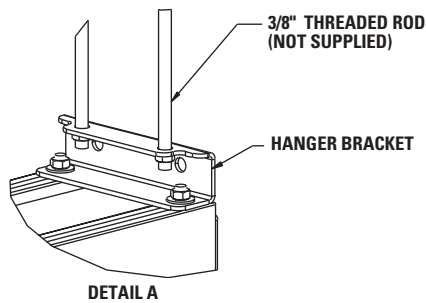
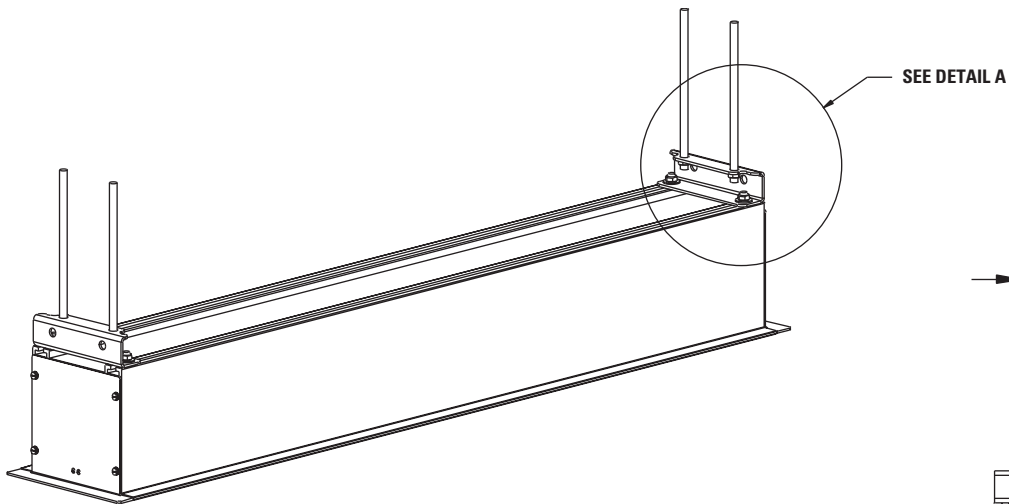
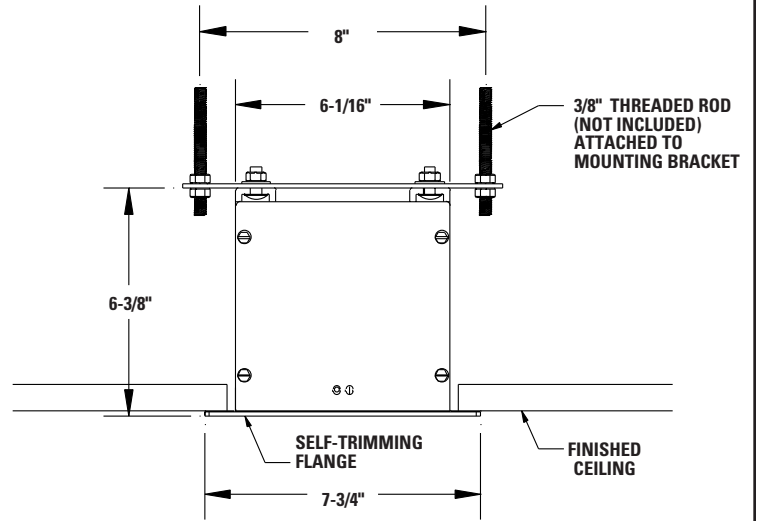
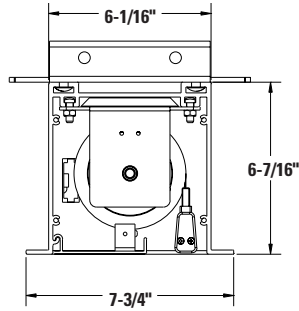
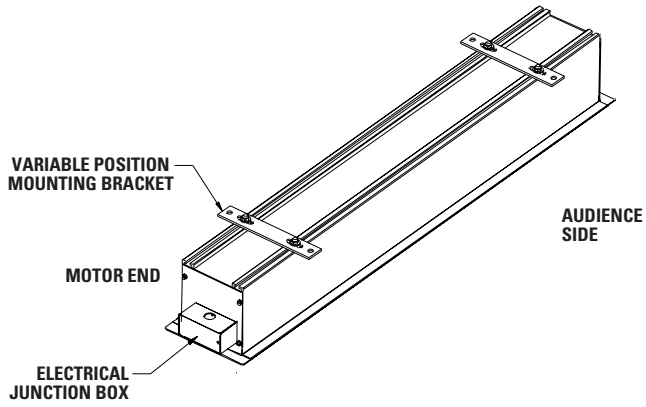

## TROUBLESHOOTING

SYMPTOM	CAUSE	SOLUTION
<p>1. Screen will not operate. Motor does <b>not</b> hum.</p>	<p>(a) Blown fuse. (b) Tripped circuit breaker. (c) No power to operating switch or junction.</p> <p>Power at junction box</p> <p>(d) Thermal overload tripped. (e) Broken wire in the <b>"down"</b> or <b>"up"</b> position. (f) Defective motor, limit switch or capacitor. (g) Capacitor burned out.</p>	<p>(a) Replace fuse. (b) Reset circuit breaker. (c) Check above. Tighten all loose wire connections. Correct any improper connections. <b>"Down" Position</b> Check for power across black and white leads. <b>"Up" Position</b> Check for power across red and white leads.</p> <p>(d) Let motor cool down for 15 minutes. Try again. (e) Check for continuity. Cut off old splice and reconnect. (f) Replace motor assembly. <b>NOTE: Motor is a sealed assembly.</b> (g) Replace motor assembly.</p>
<p>2. Screen does not stop at correct position.</p>	<p>(a) Limit switch out of adjustment.</p>	<p>(a) See Screen Adjustment section.</p>
<p>3. Noise. <b>NOTE: Screen will operate with a low-pitched hum.</b></p>	<p>(a) Squeaking, rubber end plug rubbing on motor. (b) Grinding. Foreign object in screen rubbing on roller or fabric. (c) Gear noise.</p>	<p>(a) Center roller in case. (b) Remove. (c) Replace motor assembly.</p>
<p>4. Coasting.</p>	<p>(a) Defective brake.</p>	<p>(a) Replace motor assembly.</p>
<p>5. Fabric hangs crooked.</p>	<p>(a) Screen not installed properly. (b) Fabric has backed up inside case.</p> <p>(c) Fabric is damaged.</p>	<p>(a) Check for level and plumb. (b) Adjust <b>"down"</b> limit switch slowly until roller is exposed and wrinkle comes out, then readjust for proper drop. (c) Replace fabric.</p>