

The
POWER *In*
PRESENTATION PRODUCTS



**Instruction Book for
DESIGNER CONTOUR® MANUAL**



DA-LITE SCREEN COMPANY, INC.

3100 North Detroit Street
Post Office Box 137
Warsaw, Indiana 46581-0137
Phone: 574-267-8101
800-622-3737
Fax: 574-267-7804
www.da-lite.com
e-mail: info@da-lite.com

YOU HAVE MADE A WISE SELECTION...

in choosing a Da-Lite projection screen designed and engineered to produce the sharpest, most pleasing pictures with maximum convenience.

PROTECT YOUR SCREEN by keeping it rolled in its protective case when not in use. Always examine both front and back of surface before re-rolling into case to make certain screen is free of dust, dirt or other foreign matter. Use a very soft duster brush gently to remove foreign particles.

INSTALLATION

Care in mounting and care in correct operation will mean a long and satisfactory life for your Da-Lite wall/ceiling screen. Locate the screen where the audience can best see it and where other furnishings in the room permit. Mount the screen so that bottom of picture surface, when fully extended, will be above heads of viewers.

There are three ways to install the Designer Contour® Manual: Wall Mount, Ceiling Mount, or Ceiling Hook. Procedures for each method are as follows:

Wall Mount

1. Secure the wall mount bracket to the wall at the desired height. Bracket should be fastened to wall studs or some reinforcement within the wall. Concrete or brick walls require special fasteners and anchors.
2. Make sure the bracket is level. See figure 1 for reference dimensions.
3. Keep in mind you will need at least 7/8" between the ceiling and the top of the wall mount bracket to be able to position the case on the bracket.
4. Mount the screen case on the wall bracket as shown in figure 1. Be sure the case is fully seated on the bracket. Tighten the stop screws against the wall bracket.

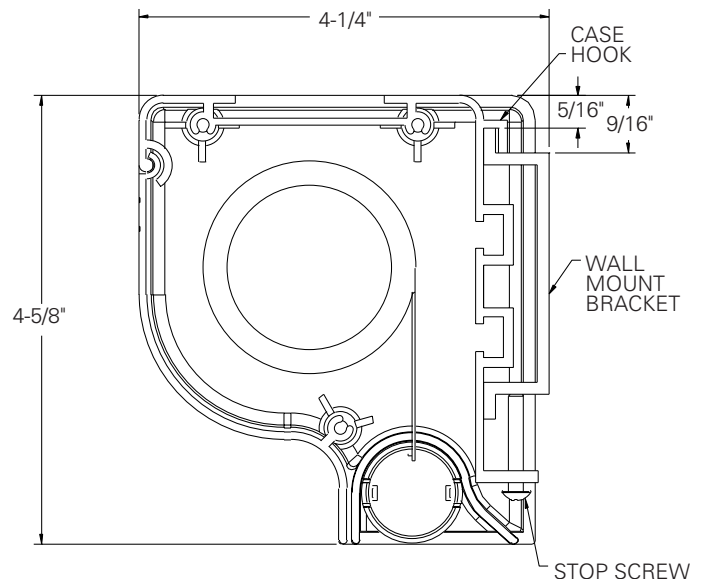

FIGURE 1

Ceiling Mount

1. Be sure the ceiling has adequate reinforcement to attach the screen brackets.
2. The top of the screen case has a channel that the ceiling mount brackets slide into. Loosen the two set screws on the brackets and slide bracket so it extends over the end of the case. Lock the brackets in place by tightening two set screws. Refer to figure 2.
3. Hold the screen case up to the ceiling and mark the hole locations. Drill holes into the ceiling and attach screen with the appropriate fasteners for your ceiling.

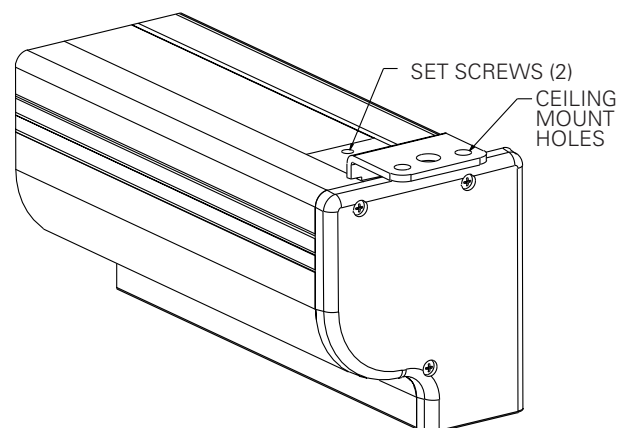

FIGURE 2

INSTALLATION

Ceiling Hook

1. Be sure the ceiling has adequate reinforcement to attach a hook anchor.
2. The top of the screen case has a channel that the ceiling hook brackets slide into. The brackets can be attached anywhere along the length of the case. Loosen the set screws on the brackets and slide the brackets to the desired location. Lock the brackets in place by tightening two set screws. Refer to figure 3.
3. Attach an S-hook to the large center hole on the bracket.

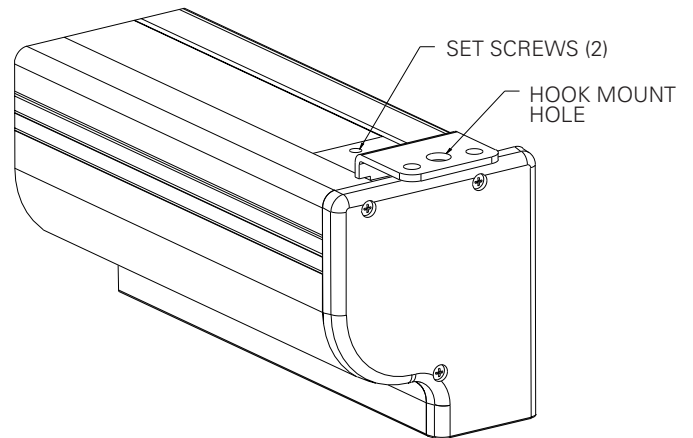

FIGURE 3

OPERATING INSTRUCTIONS

TO LOWER PICTURE SURFACE

Pull screen down all the way. HESITATE – then allow screen to retract VERY SLOWLY until it locks in place.

TO RAISE PICTURE SURFACE

Pull down on the pull bail, then release quickly. The screen will retract gently into the case.

TO ADJUST RETRACTION SPEED

Use a large flat screwdriver to turn the adjustment knob on the right end of the screen. To increase the travel speed turn counterclockwise. To decrease the travel speed turn clockwise. Adjustments should be made in half turn increments and travel speed checked before adjusting further.

NOTE: This feature is not available on some large screen sizes.

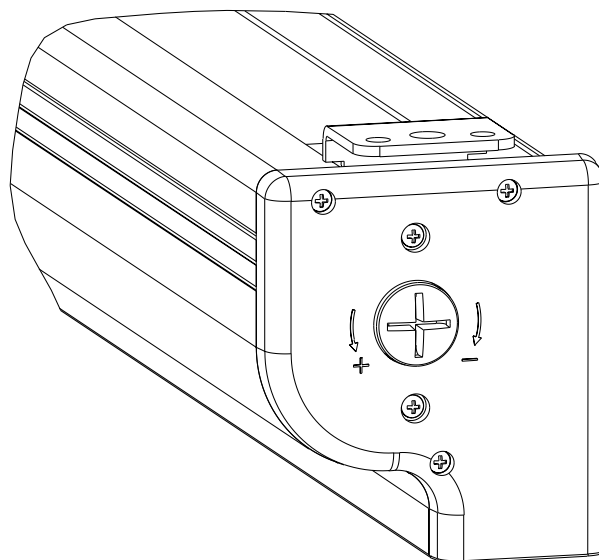

SCREEN ACCESSORIES

WALL BRACKETS

Da-Lite No. 6 and No. 11 Non-adjustable wall brackets and No. 23 adjustable extension wall brackets are ideal for keystone elimination, chalkboard clearance, or corner mounting. The screen brackets should be fastened to the studding or other solid surface and not in the plaster only.

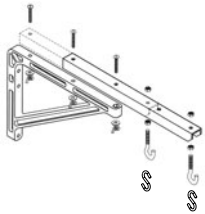

No. 23 ADJUSTABLE WALL BRACKETS

Screen can be extended 10", 14", 15³/₄", 18¹/₄", 20" or 24" from wall by wing nut and bolt adjustment.

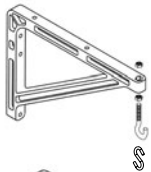

No. 11 WALL BRACKETS

Screen can be extended 10" or 14" from wall by changing position of bracket.



No. 6 WALL BRACKETS

Screen can be extended 6" from wall.

T-BAR CLIP For Dropped Ceilings

50 lb. max. load capacity.

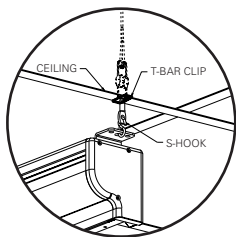

TILT LOCK For Keystone Elimination

Holds back bottom of screen in tilted position to eliminate keystone.

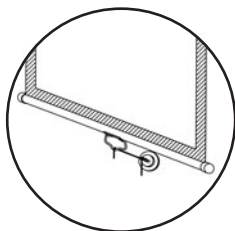

QUALITY FEATURES FOR BETTER PICTURES, EASIER OPERATION, LONGER LIFE

- Exclusive Camlok® Roller System
- Attractively styled
- Easily installed
- Economically priced
- Completely self-storing
- Ideal for worship centers, schools, family centers and industrial training rooms.

For the finest in slide, film, and video projection

DA-LITE IS MORE THAN PROJECTION SCREENS

Da-Lite Tripod, Wall and Ceiling and Electric Screens

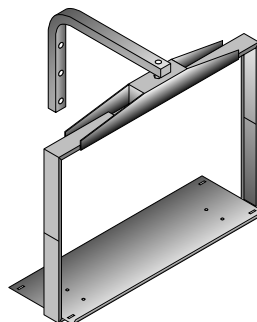
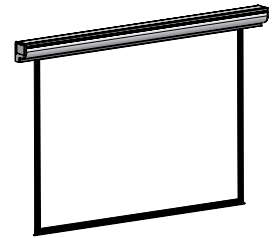

Da-Lite
Monitor Mounts

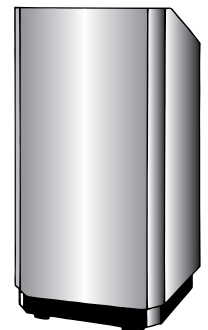

Da-Lite Lecterns



Da-Lite
Project-O-Stands
and Easels