



1650 McReynolds Avenue, N.W.
 Grand Rapids, Michigan 49504-2043
 Phone: (616) 363-4416 Fax: (616) 363-0380
 www.bulmanproducts.com

A80-05 PACKING TABLE

1. Table unit is shipped in two cartons. The first contains the table top and leg assemblies; the other contains all the hardware, shelves, dowels, brackets and any accessories which may have been ordered.
2. To begin assembly, place the tabletop upside down on a flat surface. Attach the right and left leg assemblies to the pre-attached leg channels as shown in Figure 1, View A. Next, if the two 3/4" diameter painted feed rolling dowels were purchased as an accessory (standard on the A670), insert one into the nylon bushings located on the rear of each leg about 10-1/2" from the bottom (See Figure 1). Leg assemblies will be attached using 1/4-20 x 2" hex bolts except for the back section which will attach using the 1/4-20 x 4" hex bolts through the shelf upright brackets (See Figure 2, View A).
3. Next, attach the rear brace extending from the back of one leg to the other (Figure 1). Tighten all bolts except for the 4" bolts used for the shelving uprights. Put the leveling screws and nuts in the legs as shown in Figure 1 page 2 of 4.
4. Turn the table over to the upright position. Attach the right and left shelf uprights by first removing the 4" bolts and inserting through the uprights making sure to use the spacers as shown in Figure 2, View A. The shelving can be placed at one of three heights by utilizing the first and third, second and fourth, or third and fifth drilled holes on the shelf upright. If purchased as an accessory, insert the second painted feed rolling dowel into the nylon bushings located on each upright. Those bushings can be removed and placed in the proper holes depending on the shelf height. Once in place, the bushings and painted feed rolling dowel should be parallel with the tabletop. Tighten all bolts securely.
5. Attach the left and right dividers onto the top shelf as shown in Figure 2. Next place the top shelf onto the shelf uprights as shown in Figure 2 using four 1/4-20 x 5/8" round head screws. Tighten securely.
6. Attach the bookshelf as shown in Figure 2 using four 1/4-20 x 2" bolts. Tighten securely.
7. If ordered as an accessory (standard on the A670), assemble the three hold down strips using the two #10 x 3" screws into the two threaded inserts at the rear of the tabletop.
8. If ordered as an accessory (standard on the A670), place the unpainted 1-1/4" feed dowel into the dowel sockets in the middle of the table legs.
9. If your unit is equipped with a Rotary Shear Cutter or paper cutters, attach as shown on Page 4.

<u>MFG'S PART NUMBER</u>	<u>QUANTITY</u>	<u>DESCRIPTION</u>
67010	16	1/4-20 x 2" Hex Head Grade 5 Bolts (4 installed on top channels)
67069	4	1/4-20 x 4" Hex Head Grade 5 Bolts
670101	4	1/2-13 x 2 3/4" Leveling Screw (in drawer)
378	4	1/2-13 Jam Nuts (in drawer)
398	14	10-24 x 3/8" Truss Head Machine Screws
67071	2	10-24 x 3" Round Head Machine Screws (A670 only)
1040	16	1/4" Flat Washers (4 installed on top channels)
382	2	#10 Flat Washers (A670 only)
11860	24	1/4-20 Hex Keps Nuts (4 installed on top channels) (replaces nut & lock washer)*
3800	16	10-24 Hex Keps Nuts*
11390	4	1" x 1/2" Spacers
393	4	1/4-20 x 5/8" Round Head Machine Screws

*The Keps nut is a hex nut with a free spinning lock washer attached.

A670 FULL FUNCTION TABLE, A80-35, 6 STANDARD PACKING TABLE, A80-05, 6 BASIC PACKING TABLE

FIGURE 1

VIEW A

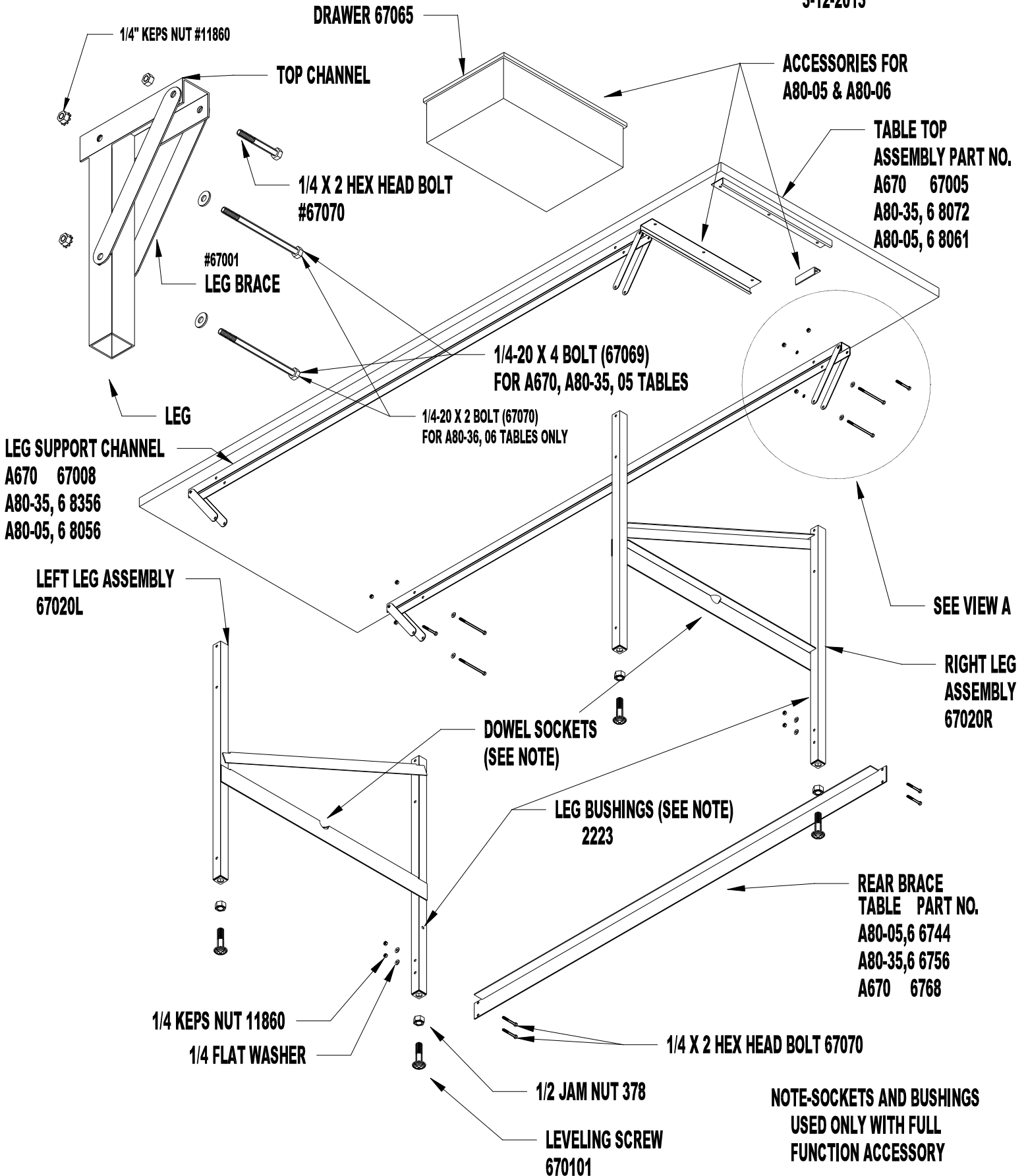

**A80-05 BASIC PACKING TABLE
SHOWN WITH *ACCESSORIES
FIGURE 2**

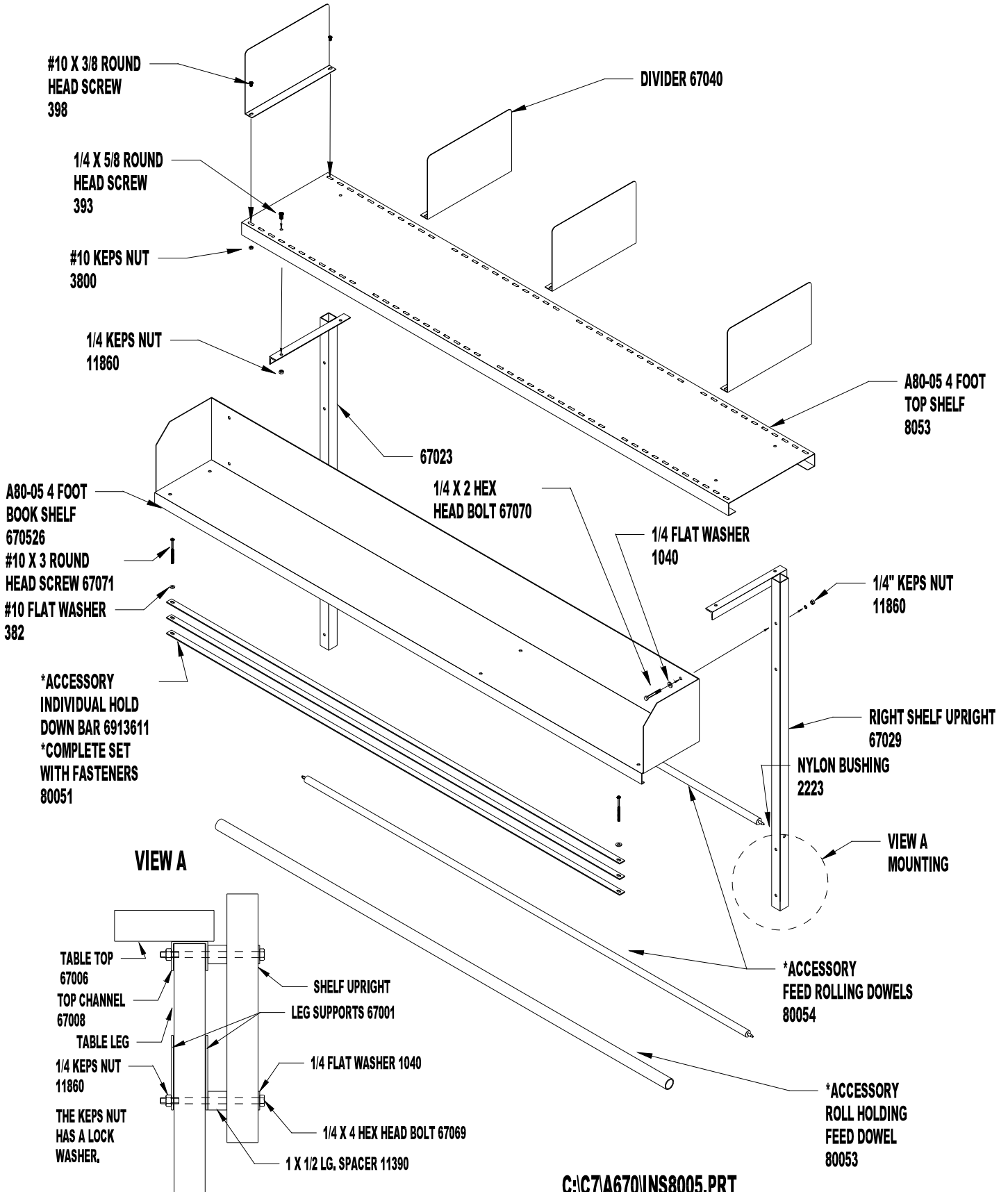

A-500 CUTTER
ACCESSORY

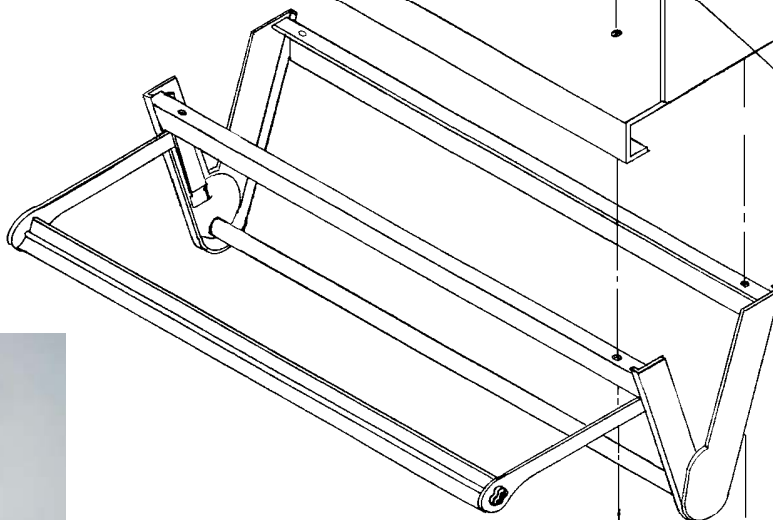

#10 x 3/8 TRUSS
HEAD SCREW
398

#10 KEPS NUT
#3800



A80-05 table shown without accessories.

ROTARY CUTTER
ACCESSORY

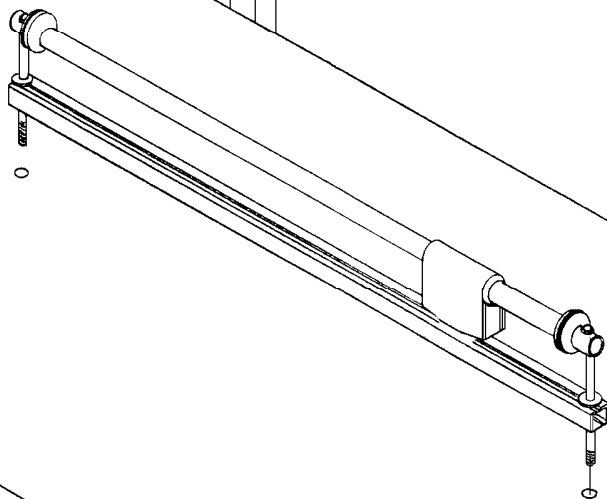

1/4 FLAT WASHER
1040

1/4-20 KEPS NUT
#11860