

BULMAN Products, Inc.

1650 McReynolds Avenue, NW
 Grand Rapids, Michigan 49504-2091
 616/363-4416, 616/363-4417 Fax: 616/363-0380
 www.bulmanproducts.com

DELUXE RAZOR-X HEAD ASSEMBLY #69500
 GUARD #6956
 KNIFE #69510

A697 DELUXE RAZOR-X CUTTER WITH HOLD DOWNS

INSTRUCTIONS

1. FASTEN THE BASE TO A TABLE USING THE 4 HOLES IN THE BASE.
2. SLIDE THE ROTARY SHEAR HEAD TO ONE SIDE OF THE ALUMINUM TRACK.
3. FEED MATERIAL UNDER 1 TO 3 HOLD DOWNS.
4. FEED MATERIAL BETWEEN THE TOP OF THE ALUMINUM TRACK & BELOW THE GUIDE TUBE TO YOUR DESIRED LENGTH.
5. SLIDE ROTARY SHEAR HEAD TO OTHER SIDE TO CUT MATERIAL.

DELUXE RAZOR-X CUTTER ASSEMBLY

PART NO.	SIZE
696241	24
696361	36
696481	48
696601	60

GUIDE TUBES	SIZE	PART NO.
	24	691244
	36	691364
	48	691484
	60	691604

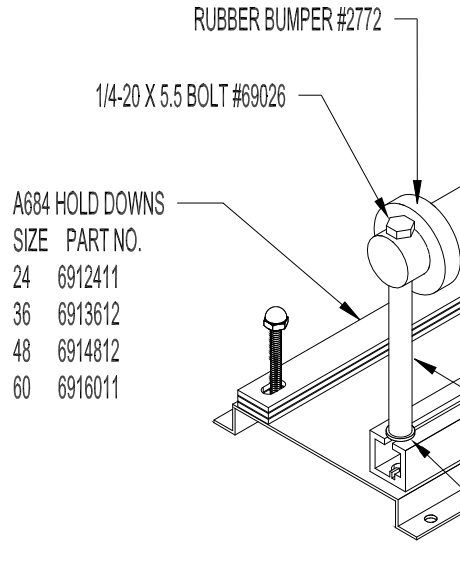

TRACK & TUBE SPACER #690210

A684 BASE	SIZE	PART NO.
	24	694242
	36	694362
	48	694482
	60	694602

© 1997 BULMAN PRODUCTS, INC. 161110/2500

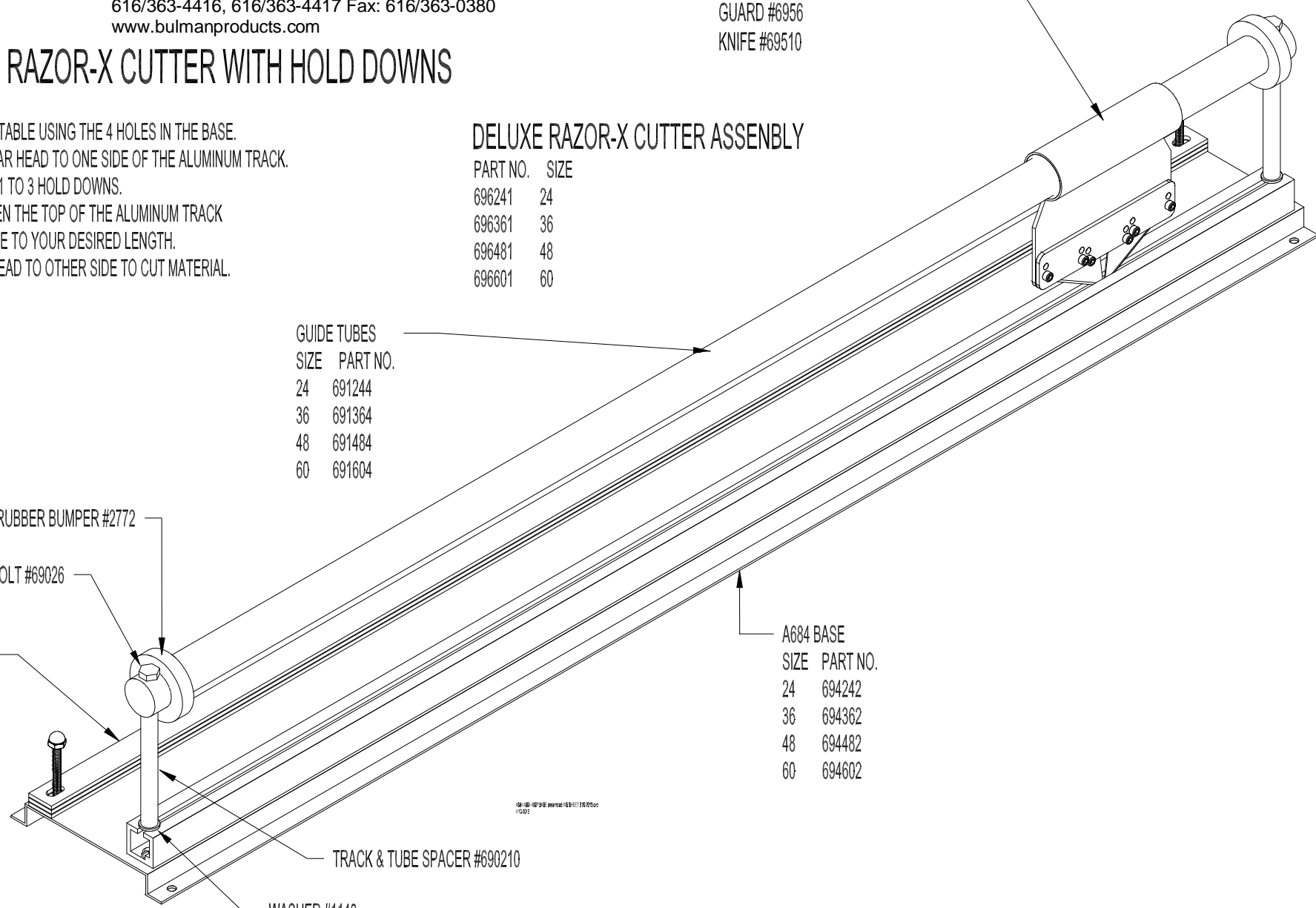

**1650 MCREYNOLDS NW. GRAND RAPIDS, MICHIGAN 49504
 PHONE (616) 363-4416 FAX (616) 363-0380**

DELUXE RAZOR-X HEAD REPLACEMENT

- 1. DISASSEMBLE ONE END OF THE CUTTER TO REMOVE THE OLD CUTTING HEAD.**
- 2. ADJUST GUARD HEIGHT FOR MATERIAL THICKNESS.**
- 3. REPLACE CUTTING HEAD AND REASSEMBLE CUTTER.
 MAKE SURE BLADES FIT BETWEEN HARDENED BLUE STEEL BLADE AND
 ALUMINUM TRACK AND DOESN'T RIDE ON FOAM. SEE DRAWING.**

**FOR ILLUSTRATION PURPOSES
 SOME FEATURES ARE NOT SHOWN.**

**THE BEARINGS ARE GLUED IN PLACE.
 THE BEARINGS ARE NOT SERVICEABLE.**

DESCRIPTION	PART NO.
DELUXE RAZOR-X HEAD ASSEMBLY COMPLETE	#69500
DELUXE RAZOR-X HEAD TOP ASSEMBLY WITH BEARINGS	#6950
DELUXE RAZOR-X ADJUSTABLE GUARD	#6956
6-32 SCREWS (6-REQ'D)	#69511
UTILITY BLADE (2-REQ'D)	#69510

A690R, A691R, A694, A695, A696 & A697 FOAM & BLADE ASSEMBLY SIZES	PART NOS.
24"	364244
36"	364255
48"	364266
60"	364261
A692 FOAM & BLADE ASSEMBLY	364266

