

# A684 RAZOR-X WITH HOLD DOWNS

## INSTRUCTIONS

1. FASTEN THE BASE TO A TABLE USING THE 4 HOLES IN THE BASE.
2. SLIDE THE RAZOR-X HEAD TO ONE SIDE OF THE ALUMINUM TRACK.
3. FEED MATERIAL UNDER 1 TO 3 HOLD DOWNS.
4. FEED MATERIAL OVER THE TOP OF THE ALUMINUM TRACK TO YOUR DESIRED LENGTH.
5. SLIDE RAZOR-X HEAD TO OTHER SIDE TO CUT MATERIAL.

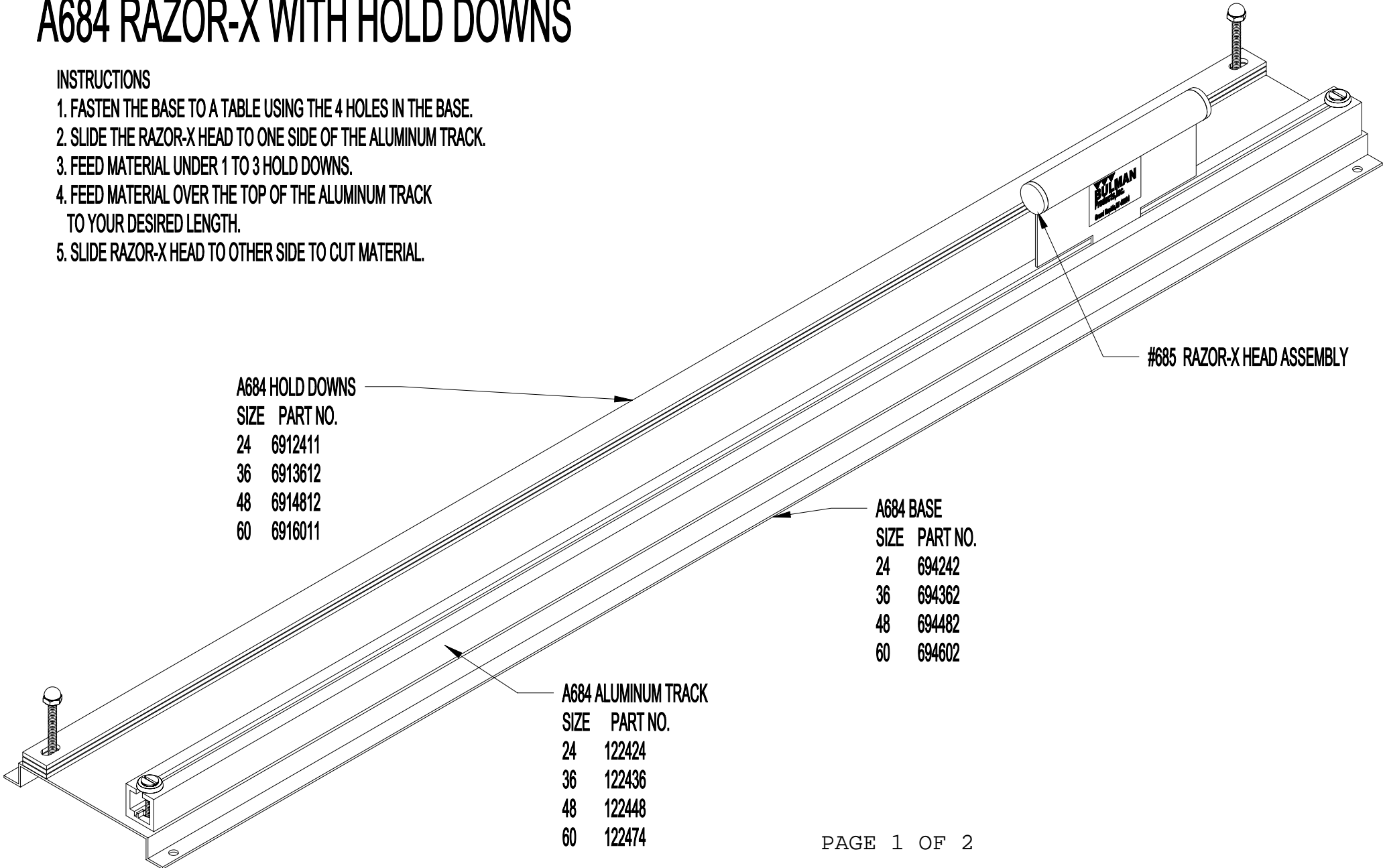

A684 HOLD DOWNS	
SIZE	PART NO.
24	6912411
36	6913612
48	6914812
60	6916011

A684 BASE	
SIZE	PART NO.
24	694242
36	694362
48	694482
60	694602

A684 ALUMINUM TRACK	
SIZE	PART NO.
24	122424
36	122436
48	122448
60	122474

1650 McReynolds Avenue, N.W.  
 Grand Rapids, Michigan 49504-2043  
 Phone: 616-363-4416 Fax: 616-363-0380  
 www.bulmanproducts.com

# RAZOR-X SLIDE KNIFE ASSEMBLY

## PART NUMBER 685

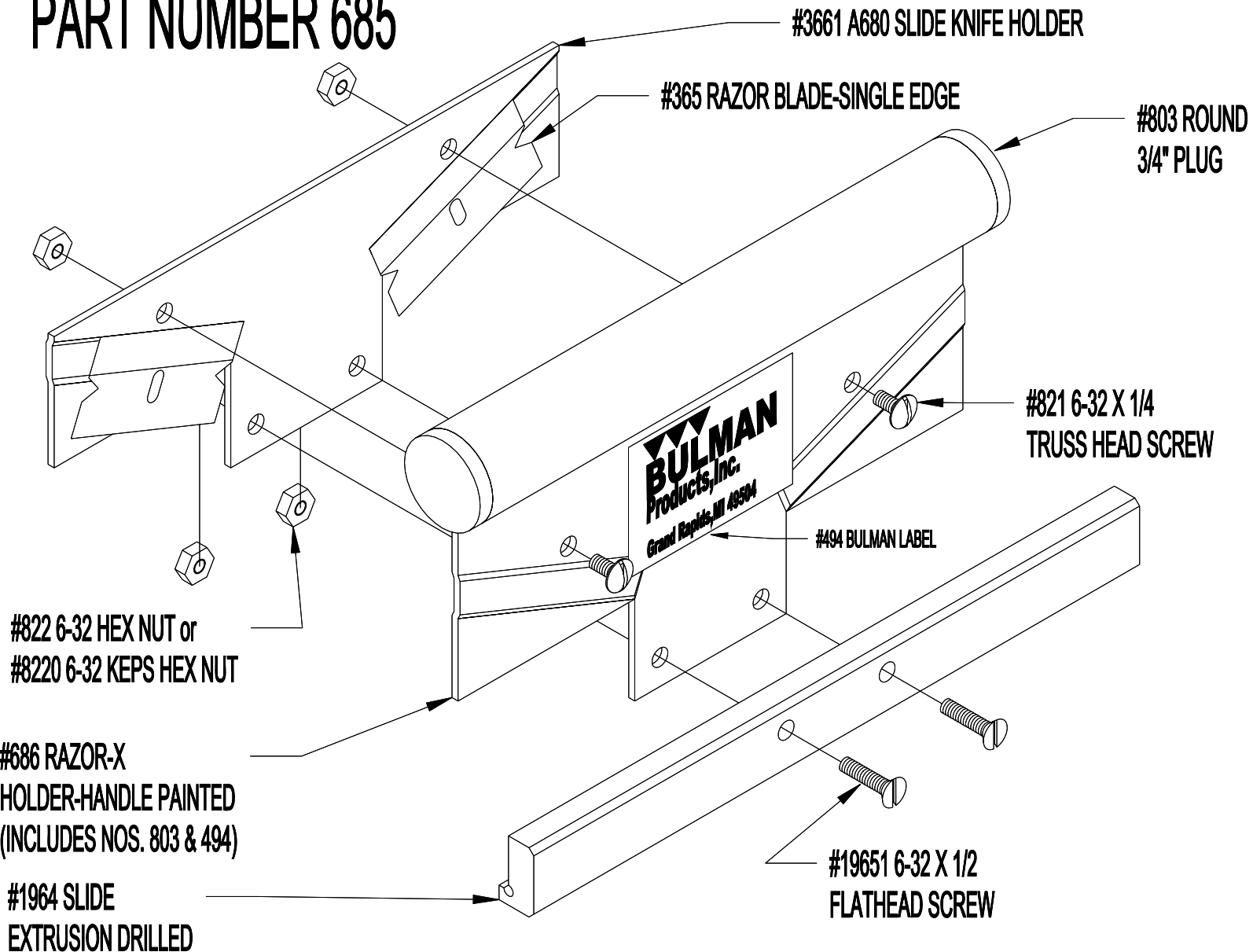

PROPERTY OF BULMAN PRODUCTS, INC.  
 C:\C7\A691R\3DRAZRHD.PRT  
 2-20-2001 DRN BY MKW